

ELECTRICAL COMMUNICATION

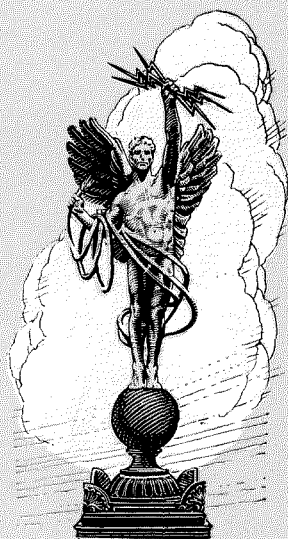

JULY
1924

No. 1
VOL. 3

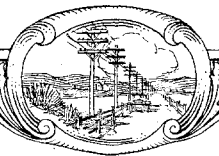

ELECTRICAL COMMUNICATION

A Journal of Progress in the
Telephone, Telegraph and Radio Art

EDITORIAL BOARD

F. B. Jewett
G. E. Pingree

E. B. Craft
H. E. Shreeve

F. Gill
E. A. Brofos

J. L. McQuarrie
P. K. Condict

J. F. Rhame, Editor

Published Quarterly by the

INTERNATIONAL WESTERN ELECTRIC COMPANY
INCORPORATED

195 BROADWAY, NEW YORK, N. Y., U. S. A.

Charles G. DuBois, President

George C. Pratt, Secretary

J. W. Johnston, Treasurer

Subscription \$1.50 per year; single copies 50 cents

Volume III

JULY, 1924

Number 1

CONTENTS

| | |
|---|----|
| SCIENCE AND BUSINESS..... | 3 |
| <i>By J. J. Carty</i> | |
| MAKING THE MOST OF THE LINE..... | 8 |
| <i>By F. B. Jewett</i> | |
| EUROPEAN INTERNATIONAL TELEPHONY..... | 22 |
| <i>By F. Gill</i> | |
| TELEPHONE TRANSMISSION STANDARDS IN EUROPE..... | 28 |
| <i>By L. C. Pocock</i> | |
| THE TRANSMISSION UNIT..... | 34 |
| <i>By R. V. L. Hartley</i> | |
| AUDITORY MASKING AND DYNAMICS OF THE INNER EAR.. | 43 |
| <i>By R. L. Wegel and C. E. Lane</i> | |
| MODERN METHODS IN TRAIN DISPATCHING..... | 57 |
| <i>By J. C. Latham</i> | |
| WAVE FORM EXAMINATION WITH CATHODE RAY OSCILLO- GRAPH..... | 69 |
| <i>By N. V. Kipping</i> | |

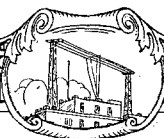



The new home, in Washington, D. C., of the National Academy of Sciences, devoted to pure science, and of the National Research Council, devoted to pure and applied science.

Science and Business

By GENERAL J. J. CARTY

Vice-President, American Telephone and Telegraph Company

Note.—On May 8, General Carty addressed the United States Chamber of Commerce in convention at Cleveland, Ohio. The talk was made from the headquarters of The Chesapeake and Potomac Telephone Company at Washington and carried to Cleveland over a telephone circuit, where all present in Keith's Palace Theater were able, by means of the Public Address System, to hear the address.—EDITOR.

I HAVE been asked to address the Chamber on the subject of "Science and Business." More than we yet realize, the future of American business and commerce and industry is dependent upon the progress of science.

The advancement of science is accomplished by scientific research of two kinds. The first is research in pure science, and the second is research in applied science. In the first of these—that relating to the domain of pure science—research is conducted solely for the sake of extending the boundaries of knowledge. In the second, research is conducted for the purpose of applying to practical uses the new knowledge discovered by the pure scientists.

The investigators in pure science are guided by a philosophic purpose directed to the discovery of truth and the advancement of learning. They may be compared to explorers who discover new continents or islands or hitherto unknown territory. They are continually seeking to push forward the frontiers of knowledge.

The work of the pure scientist is conducted without any immediate utilitarian motive, for, as Huxley has well said, "that which stirs their pulses is the love of knowledge and the joy of the discovery of the causes of things, the supreme delight of extending the realm of law and order ever farther towards the unattainable goals of the infinitely great and the infinitely small, between which our little race of life is run."

The pure scientists are to be found in our universities and in our very small number of institutions for research in pure science. They are the advance guard of civilization. By their discoveries, they furnish to the engineer

and the industrial chemist and other workers in applied science the raw material to be elaborated into manifold agencies for the amelioration of the condition of mankind, for the advancement of our business, the improvement of our industries, and the extension of our company.

Unless the work of the pure scientist is continued and pushed forward with ever-increasing energy, the achievements of the industrial scientist will, in the course of time, diminish or degenerate. Many problems now confronting us cannot be solved by the industrial scientist alone, but must await further fundamental discoveries and new scientific generalizations. When considered with reference to a single branch of industry, no particular discovery in pure science is likely to appear at first to be of appreciable benefit, but when the total contributions of pure science are reviewed with regard to the industries as a whole, it is found that they have become of incalculable value through adaptations to practical use by the commercial and industrial scientists.

While the discoveries of the pure scientists are of the greatest importance to the higher interests of mankind, the practical benefits flowing from them, though certain, are usually indirect, intangible, or remote. From its very nature, pure science cannot support itself. Nevertheless, it must be conducted regardless of its lack of pecuniary returns. The obligation of the public to support researches in pure science and the advantages which are certain to flow from such support are incalculably great.

Michael Faraday, working in England, and Joseph Henry, working here in America at the same time, made fundamental discoveries in pure science underlying the art of electrical engineering. If we were to subtract from our present knowledge the contributions of these two great men and perhaps those of one or two others, the wonderful structure which our

applied scientists, the electrical engineers, have reared upon the foundation of knowledge provided by these investigators, would disappear.

But, notwithstanding these practical results which sooner or later are sure to follow from their work, the question for the pure scientists is not so much what use can be made of their discoveries, but rather what message do they bring, what truths do they reveal, what laws do they establish?

An experiment in science is but an hypothetical question put to nature. She will answer truthfully every such question that we ask. She will make known to us all her secrets if we have but the skill properly to frame our questions and the wit to understand her answers.

An English statesman before whom Faraday performed his fundamental experiment in electromagnetism, asked of him the forbidden question, "What use is it?" Faraday, without revealing the irritation which he must have felt, said, "Some day it may be developed so that you can tax it." Faraday was a good prophet, for upon his fundamental discoveries and those of the American Joseph Henry, and I might include one or two others, there has been erected by our applied scientists the entire art of electrical engineering. Truly, these discoveries have been developed, for today mankind is in possession of electrical property valued at more than twenty billions of dollars, and evidence is not lacking that others besides Faraday's statesman are busy with the taxing of it.

While the people of the United States and of other countries are under great obligations to support the work of the pure scientist, and while ultimately they will derive immense benefit therefrom, there is not the time at my disposal to develop this idea further.

My principal purpose today is to bring to the attention of the members of the Chamber the very great advantages which will come to them from establishing within their own organizations departments for scientific development and research devoted to the practical purpose of improving their own business.

And now, coming to the work of the applied scientists, it can be said with truth that, con-

sidering the art of electrical engineering as it exists today, if we were to take away the contributions of the applied scientists, that which would be left would make a sorry showing. The entire art of telephony would disappear, and all of these wonderfully co-ordinated social and business activities depending upon that means of communication would instantly be paralyzed.

In electric lighting and power, and transportation, the contributions of engineers and other applied scientists have been so important and so numerous that it is impossible to picture the chaos which would result if by some black magic their wonderful work should be undone. All of this work, it should be noted, has been accomplished within the last fifty years.

The importance of establishing within their own organizations departments of applied science or, as they are sometimes called, departments of development and research, has been better appreciated in the chemical and metallurgical and electrical industries than in most others, and the results which they have secured for their organizations have abundantly justified the establishment and maintenance of such departments.

I can best illustrate my point by a concrete example drawn from my own experience in the telephone art, which has covered a period of more than forty years.

The Department of Development and Research which is conducted under my direction had very humble beginnings. At first, about the year 1875, it consisted of but one man, and then two, and then others were added. As the years went on, the work of the department proved to be so important and became productive of such good results that the number of workers was steadily increased until at the present time the total personnel of the department includes about 3,000 workers, about half of whom have scientific or engineering training, a large proportion being graduates of our American colleges and universities. The remaining personnel consists of mechanics, draftsmen, clerical and administrative forces.

In the beginning it was very difficult for us to obtain the necessary financial support even

for the very small personnel and the limited laboratory equipment employed. At the present time, the budget of the department amounts to about \$8,000,000 a year, and the laboratories alone occupy a large 13-story building providing about ten acres of floor space.

Unlike the laboratories of the pure scientists established for the discovery of fundamental laws and new truths without regard to their immediate utility, these laboratories are devoted to a severely practical purpose. They are organized on a strictly business basis, and the work conducted in them is directed to no other purpose than improving and extending and conducting in a more economical manner the service which we render to the public.

The criterion which we apply to the work conducted in these laboratories is that of practical utility. Unless the work promises practical results it is not undertaken, and unless as a whole the work yields practical results it cannot and should not be continued. The practical question is, "Does this kind of scientific research pay?" If it does, it should be continued. If it does not, it should cease.

A consideration, therefore, of the practical results which have been obtained from this method of working will help us to a better understanding of our subject.

In 1875, the entire telephone plant of the world could have been carried in the arms of a child. It consisted of two crude telephones and about 100 feet of wire over which Alexander Graham Bell spoke to his assistant, Thomas A. Watson. Starting with such feeble instruments, the personnel of these laboratories by incessant experimentation and the expenditure of immense sums of money have created a new art, inventing, developing, and making improvements great and small in telephone, transmitter, line, cable, switchboard and every other piece of apparatus and plant required in the transmission of speech.

As one of the results of the cumulative improvements in the art coming from this unceasing organized effort, Dr. Bell, in the year 1915, was enabled to talk once more to Mr. Watson through the original historic instrument, although they were thousands of miles

apart, the one at San Francisco, and the other at New York.

By the work of the applied scientists, these two original telephones have increased marvelously in numbers and in efficiency, and the first telephone line of 100 feet in length has been expanded into a network covering the continent, until the telephone system of the United States alone comprehends over 34,000,000 miles of wire, and over 15,000,000 telephone stations located throughout the whole country. The plant composing this system is conservatively valued at more than two billions of dollars.

Pressing on to achieve still greater distances, the staff of these laboratories transmitted for the first time the human voice without the use of wires from Washington across the North American continent to San Francisco and even far out into the Pacific Ocean to the Hawaiian Islands where words spoken at Washington were plainly heard.

By this same apparatus and by these same scientists, intelligible speech was for the first time transmitted across the Atlantic Ocean from Arlington, Va., and heard at Paris. This was done in the year 1915. But still higher achievements now lie immediately before us.

To this work done in applied science, the people of the United States and indeed of the world are indebted for the highly developed telephone apparatus and methods now available for use in all countries, but in our own to an extent far greater than in any other land.

But it is not alone by these general results that I ask you to judge of the importance to the members of this Chamber of employing the services of the applied scientists. I will give some concrete examples showing definite pecuniary returns.

From their very nature, not all the advantages resulting to the telephone system from its researches in applied science are capable of definite evaluation. For example, no one can accurately appraise the value to the public of those improvements without which the present extensive telephonic system of the United States could not have been created. Such figures would be speculative and even when

moderately stated would be so large as to be unbelievable.

But I have made a survey of the work done during the period from 1900 to 1920, and choosing only ten items concerning which definite data could readily be obtained, the specific savings amount in round figures to \$500,000,000. This means that the plant of the telephone system, if it could have been constructed at all, would have cost that amount more than it has cost. If we were to broaden our inquiry so as to include many other items and to cover the period prior to 1900, I feel sure that this figure would be more than doubled.

The savings represented by these figures accrue to the public in a much larger measure than to the Company, for without these scientific developments the service which is now rendered to the public could be given, if at all, only at prohibitive cost.

I think I have said enough to show that the establishment of a department of applied science has been of great advantage to the telephone system and of incalculable benefit to the public.

But the benefits flowing from the application of science to the telephone tell but a part of the story. The scientific development of the telephone gave a great stimulus to the whole electrical art, and following the invention of the telephone came the beginnings of the electric light and power industries. Many of the concerns engaged in these industries likewise established departments of development and research, and the results which they have accomplished by taking advantage of the services of applied scientists have been astonishing in their magnitude and importance.

The results which have been achieved by scientific workers in applied chemistry have also been of extraordinary value to the American industries. So great indeed have been the benefits to industry and business and commerce through the employment of practical scientific methods that the value of applied science to our practical affairs has been abundantly established.

But the number of concerns which have thus far adopted scientific research as an in-

tegral part of their organizations is very limited indeed, and these methods and these ideas which have proved of such great importance in some of our industries have not yet been appreciated and adopted generally. In fact, I think it is true to say that only a beginning has been made.

The message therefore which I have to deliver to the members of the Chamber today is that Science can be of immense help to Business, and that it is only with the aid of Science that American Business can keep pace with the rapid advances which are now being made throughout the world.

How can the members of this Chamber find out for themselves in what way science can help their business? I am sure that those concerns that have already established departments of scientific development and research will be glad to give to members of the Chamber information concerning their methods and organization.

In addition to this, I wish to call attention to the fact that at Washington are the headquarters of the National Academy of Sciences devoted to pure science, and the National Research Council devoted both to pure and applied science. The latter institution is not organized for the purpose of conducting research for any particular business concern, but it is organized so that together with its other functions it may give advice and help to all of those seeking to find out in what way science can aid their business.

I think it is a matter of deep significance that just at this time the new building which houses both the National Academy of Sciences and the National Research Council has been dedicated. Already I have had conversations with officials of the Chamber of Commerce, the National Academy of Sciences, and the National Research Council looking to the establishment of helpful relations between these three great national bodies. I am a member of all three of them. I am sure that some plan will develop whereby through co-operation between science and business the results which have been obtained in a few industries may become widespread, and that the day will

come when a department of development and research will be considered as essential to every industry as is the sales department, or accounting department, or any other department of its organization.

At the dedication of the National Academy of Sciences and National Research Council Building in Washington a few days ago, the President of the United States gave a notable address during which he said: "This magnificent building now being dedicated to science predicts a new day in scientific research. A

new sun is rising. It is destined to illuminate the scientific world by illuminating this hall." That these prophetic words of the President will come true, all scientists must agree.

I am sure that this new sun, which is rising as surely as the sun will rise tomorrow, will illuminate also the new home of the United States Chamber of Commerce at Washington. I hope that in this new light the Chamber will investigate the boundless possibilities which must come from the employment of Science in the service of Business.

Making the Most of the Line¹

By F. B. JEWETT

Vice-President, Western Electric Company, Inc., and International Western Electric Company

INTRODUCTION

Abstract: MAKING THE MOST OF THE LINE refers broadly to the practical utilization of frequency bands in communication engineering. I shall attempt to explain the character of the currents employed for communication purposes and endeavor to show how completely the available range is employed to carry on the various functions of the service, including simultaneous operation of telephones and telegraphs, signaling and talking. Finally, I shall describe the principles of carrier current operation by which we obtain as many as five telephone connections or twenty telegraph circuits over the same pair of wires.

To engineers interested primarily in lighting and power problems the question of frequency after it is once decided upon for a particular system has in the past been of secondary interest only. I use the phrase "in the past" advisedly, for the very things which make frequency of such paramount importance in the communication field are making it of increasing importance in the power and lighting field, not alone because of the increasing reactions of power service on communication service but also because it is clear that many of the principles developed in the communication field are to find a place in the power and lighting field.

To the communication engineer frequency is the key-stone of the whole engineering structure and in many of his networks he must consider the proper transmission and control of the range of frequencies from zero to 30,000 cycles per second or more. The upper limits of this range carry the problems of line transmission well into the realm of the frequencies employed in radio communication. In fact the mechanisms in the two fields of communication are quite similar in their fundamental aspects, although those employed in line working are of necessity far more elaborate and complex than those required for the relatively simpler conditions met with in radio. The communication engineer assigns separate frequency bands to perform separate functions, segregates and directs them by selective means and frequently transmits them over the same line circuit simultaneously without interference.

In view of the great differences which exist between the problems which confront the communication engineer and the power engineer, and in order that we may have a common foundation on which to build our picture, I am going to review briefly a few elementary physical facts which it is necessary that we have clearly in mind if we are to achieve the result we desire. In this way we shall be in agreement as to the use of terms so that what follows will I trust be more understandable.

IN ANY discussion of the electrical transmission of intelligence we have to consider various phenomena related to electric currents. Now an electric current is the flow, or motion, of a charge of electricity through a conductor. Such motion of electricity through a conductor is not unlike the motion of matter through space. Under a constant driving force

motion is uniform so long as it is impeded by a constant retarding force. This is true for the motion of water in a pipe, as it is pumped against a constant pressure by a constant driving force. It is also true for the flow of electricity as it is forced through a fixed resistance by a battery of constant potential. Such uniform motion of an electric charge results in what we know as a direct current.

Under certain conditions the motion of an electric charge is analogous to the motion of a

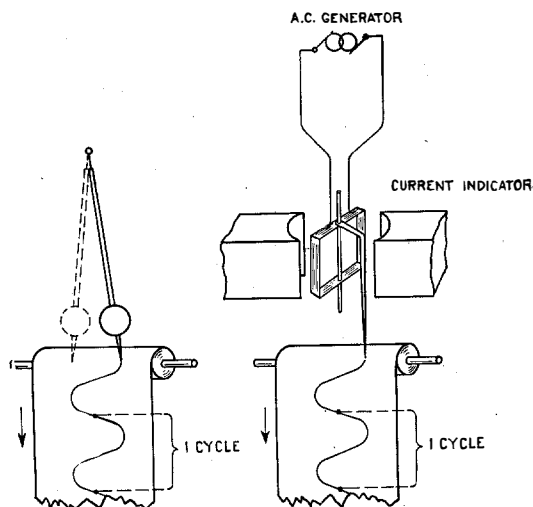

Figure 1—Analogy Between Motion of a Pendulum and Motion of a Charge of Electricity

pendulum. The direction of motion reverses at regular intervals and the velocity—or the amplitude of the current—increases and diminishes in exactly the same manner as does the velocity of the pendulum bob. Such a current is said to be an alternating current.

In order to obtain a clearer picture of such a current we may refer to Figure 1. Let us imagine that an ordinary pendulum be provided with a pencil so arranged that, as the pendulum swings the pencil is drawn back and forth across the sheet of paper. Suppose further, that the sheet of paper be moved at a uniform speed in a direction at right angles to the motion of

¹ Paper presented before the Philadelphia, Pa., Section of the American Institute of Electrical Engineers, Oct. 17, 1923.

the pendulum. The resulting trace will give us a picture of the relation between the motion of the pendulum and time. Now let us arrange another pencil on an instrument which shows the instantaneous amplitude of an electric current. If this instrument is connected to a generator of alternating current the resulting trace, upon a uniformly moving paper, will be identical in form to that given by the pendulum. Such motion, whether of matter or of an electric charge, is said to be sinusoidal. The trace on the paper is often referred to as a sine wave.

The time which elapses between the instant when the pendulum, or the charge, has a certain displacement and direction of motion and the instant when it next has the same displacement and the same direction of motion is known as the period of the wave. The motion throughout a single period constitutes a cycle. The number of cycles executed in a second of time is spoken of as the frequency. In discussions concerning an alternating current, that is, a current having a sinusoidal wave-form, we shall refer to its frequency as so many "cycles per second" or, more briefly, as so many "cycles."

With this preliminary survey of our vocabulary we may proceed to a consideration of the nature of the currents encountered in electrical communication. Let us start a pair of wires, or a line, connecting two points between which

receiving end, following some prearranged code, will be significant to an observer.

To study the currents present in such a system we may again employ a moving paper tape and a device for registering the instantaneous value of the current. If the key be opened and closed at regular intervals, the resulting current

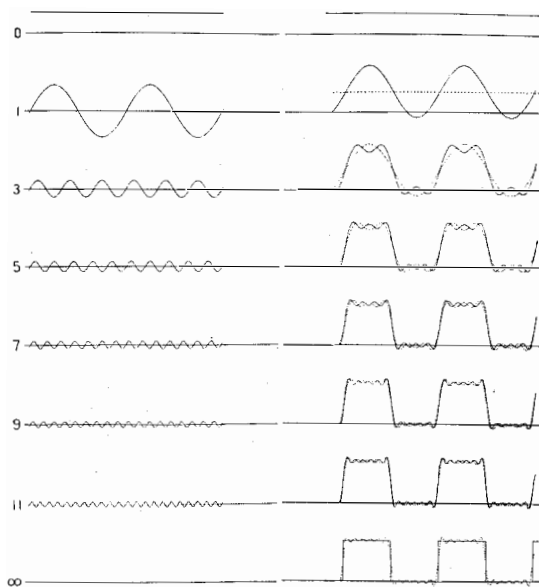

Figure 3—Composition of Square-topped Wave

will vary in amplitude with respect to time, as shown by the curve traced by the pencil of the indicator.

It is apparent that such a wave differs radically from the sinusoidal wave of a single frequency alternating current. As a matter of fact, a mathematical analysis of this square-topped wave has shown that it is composed of a considerable number of sine wave alternating currents having a definite frequency and amplitude relation to each other (Figure 3). The analysis further shows that there is present a continuous direct current. The several waves shown at the left of this diagram indicate a few of the many current components present in the square-topped wave obtained from our telegraph system. That these components add together to give the actual wave on the line is shown by the traces at the right of the diagram. Each wave here is the sum of the sine wave immediately opposite and all the preceding components. It is apparent that, by the time

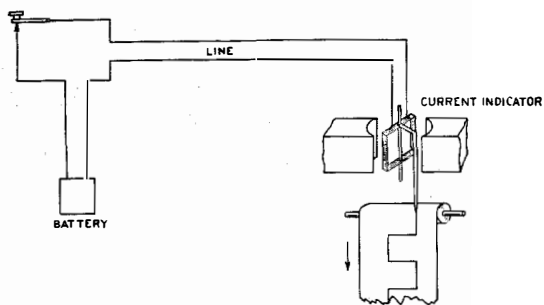

Figure 2—Diagram of an Elementary Recording Telegraph Circuit Showing Square-topped Wave Received Over a Line Which Has No Capacity or Inductance

we wish to communicate (Figure 2). At one end let us provide a battery, or source of constant potential, and at the other end an instrument for indicating the flow of electric current. In order to transmit intelligence it is also necessary to include a key to so control the current that the resulting behavior of the instrument at the

we have added together the first six alternating currents plus the direct current component, we have approached the form of the wave given by the telegraph key. If we had included a considerably greater number of alternating current components we would have obtained the trace shown at the lower right-hand corner.

A convenient way of recording the current components making up a particular complex wave is shown in this chart (Figure 4). Each vertical line corresponds to a single frequency component of the complex current which we are

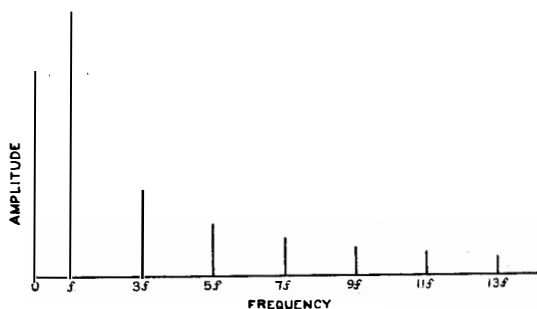

Figure 4—Chart of Current Components Present in Square-topped Wave

considering. The position of the line with respect to the frequency scale indicates the frequency of the component and the height indicates the relative amplitude. On such a scale a direct current appears as having zero frequency. This particular chart indicates the current components present in the square-topped wave which we have just discussed. It will be noted that currents having frequencies several times that of the frequency at which the key is operated must be transmitted over the line if the current at the receiver is to have the same waveform as that originated by the key.

Now it is obvious that we cannot transmit intelligence by opening and closing the key indefinitely at regular intervals, but that we must follow some prearranged sequence of irregular impulses. A complete analysis of the current components occurring during the transmission of such irregular impulses is extremely complicated. The important fact is that we find it necessary to employ an electrical system capable of transmitting all frequencies between zero and some frequency several times greater than the maximum frequency at which the key

is operated. In commercial telegraphy, with hand sending, frequencies above 40 cycles are of little importance. With a multiplex printer it is desirable to retain frequencies as high as 100 cycles.

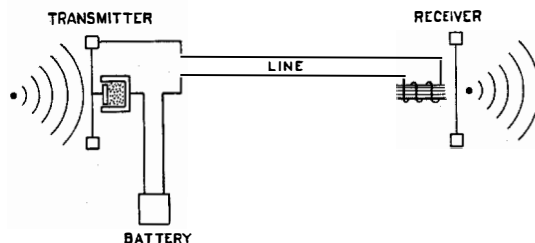

Figure 5—Diagram of an Elementary Telephone Circuit Without Capacity or Inductance in the Line

If we wish to transmit speech electrically it is necessary to replace the key of our telegraph system by some current-controlling device capable of varying the amplitude of the current in accordance with the acoustical wave sent out by the speaker (Figure 5). At the receiving end we must use a device capable of sending out an acoustical wave the characteristics of which are determined by the received current. We can investigate the currents present when such a transmitting device is employed by replacing the key of the system which we have already considered by a carbon button transmitter. This

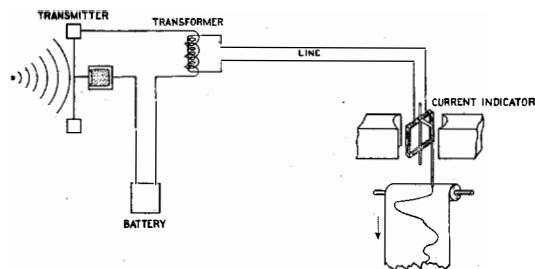

Figure 6—Diagram of an Elementary Telephone Circuit With Transformer and With Current Indicator Replacing Receiver

transmitter contains a diaphragm which is moved back and forth by the acoustical wave thus varying the pressure, and therefore the resistance, of a column of granular carbon included in the electrical circuit.

The direct current component is prevented from flowing over the line by the introduction of a transformer. This transformer, however, passes all sine wave components resulting when

a speech wave falls upon the transmitter. If we retain our registering current indicator (Figure 6) it will be possible to secure a trace showing

than the analysis of the waves occurring in telegraphy. There are, however, devices known as current analyzers which separate the various sinusoidal components and measure their amplitude and frequency. The results of such analysis (Figure 7) of the electric currents produced by a number of representative sounds are shown here. This analysis tells us that, in order to transmit speech, we must employ currents which may have any frequency between 300 and 2,800 cycles per second. In the case of high-quality speech transmission for loud speakers, or for the transmission of music, it is necessary to employ currents having frequencies between 100 and 6,000 cycles per second.

The preceding discussion has indicated the nature of the alternating currents present when the source of the electrical energy supplied to our communication system is of constant potential. It is of interest to consider the currents present when the energy is supplied in the form of an alternating current. Let us return to our simple telegraph system and replace the battery by an alternating current generator (Figure 8). If we

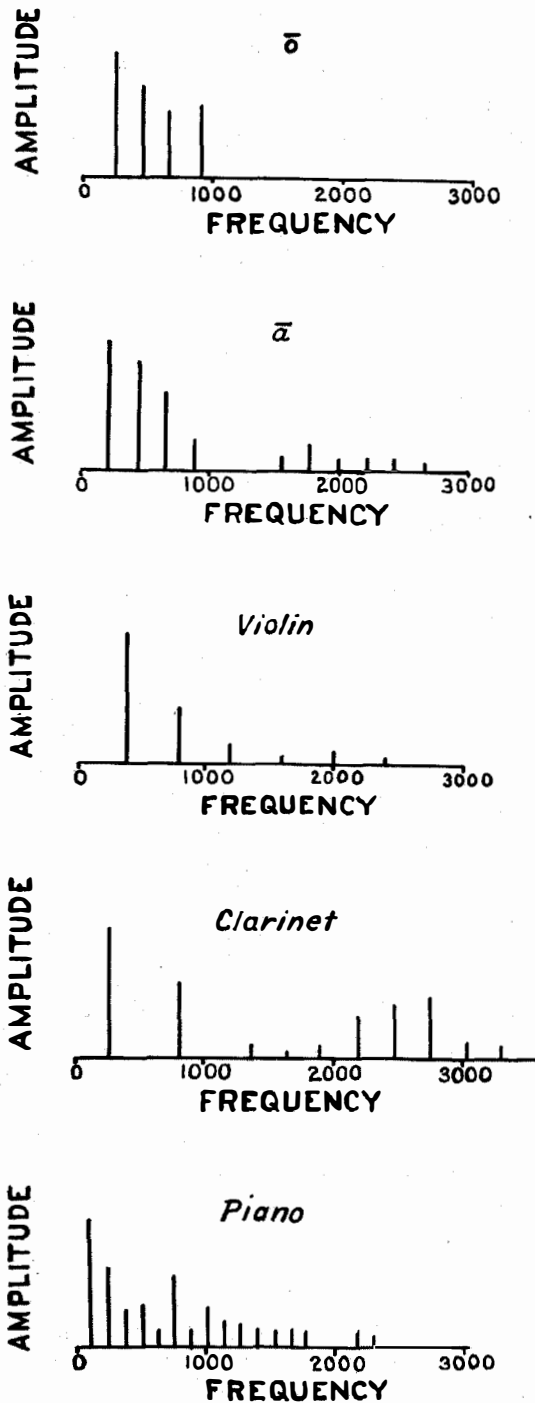

Figure 7—Chart of Components Present in Various Representative Sounds

the wave-form of the actual line current. The analysis of such waves is obviously more difficult

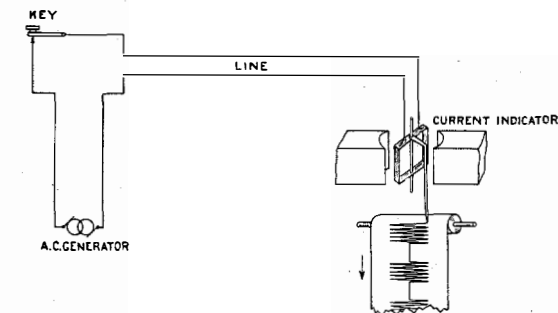

Figure 8—Diagram of an Elementary Recording Carrier-Current Telegraph Circuit Showing Signal Received Over a Line Which Has No Capacity or Inductance

open and close the key at regular intervals, as we did before, the trace, which indicates the resultant current flowing in the system, is as shown on the tape. The sine wave components constituting this wave may be determined either by actual measurement with a current analyzer or by a mathematical analysis. The results in either case are as indicated on the chart (Figure 9). It will be noted that there are here two groups of current components, one lying on either side of the current delivered by the generator. It will be further noted that the group

of currents lying above the frequency of the generator is identical with the group of currents produced in the direct current telegraph system except for its position upon the frequency scale. The lower group is in effect a mirror image of the upper group. In such a system the current de-

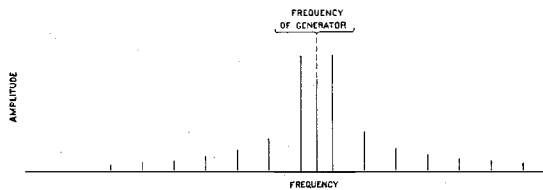

Figure 9—Chart of Current Components Present in Carrier-Current Telegraph Signal

livered by the generator is spoken of as the carrier current. The group of currents lying above the carrier on the frequency scale is the upper side band and the group of currents lying below the carrier is the lower side band.

The final step in our study of the currents employed in electrical communication is to consider the effect of varying the amplitude of a

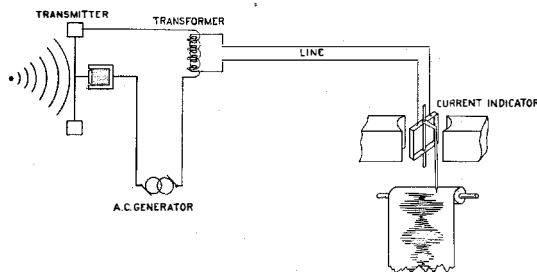

Figure 10—Diagram of An Elementary Carrier-Current Telephone Circuit Without Capacity or Inductance in the Line and With Current Indicator Replacing Receiver

sine wave alternating current in accordance with a speech wave. Figure 10 shows the appearance of such a wave. In speaking of the process of varying the amplitude of an alternating current, we generally refer to it as "modulation." Here again (Figure 11) an analysis shows that the components resulting from the modulation of an alternating current by a speech wave comprise two groups of current components lying on either side of the carrier. The arrangement of the various members of either group, with respect to the carrier, is the same as the arrangement of the components in the direct current telephone system with respect to the zero end of the frequency scale.

In practice it is found most convenient to obtain a modulated alternating current from an acoustical wave in two steps. The first employs a device, such as the familiar transmitter, for varying the amplitude of a direct current in accordance with the acoustical wave, thus obtaining the group of alternating currents which we found to be present in our direct current telephone system. This current is then impressed upon a second device, known as a modulator, where it is caused to vary the amplitude of an alternating current, or carrier current. The resulting complex wave, as we have seen, is made up of two groups of frequencies arranged

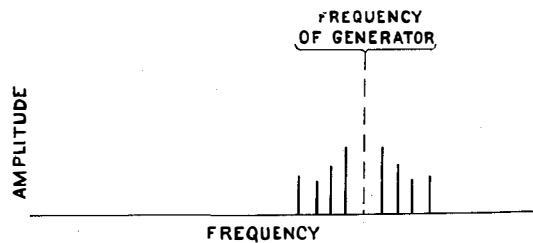

Figure 11—Chart of Current Components Present in a Representative Carrier-Current Telephone Signal

symmetrically about the carrier. For each current component present in the direct current telephone system, there are two components present in the alternating current telephone system, each of these latter components differing in frequency from the carrier by the frequency of the original component in the direct current system.

At the receiving end of a system employing such currents for transmission it is necessary to provide a device which, when controlled by a modulated carrier current, delivers a current wave similar to that impressed upon the modulator. Such a device may properly be called a remodulator.

The modulators and remodulators in most common use employ vacuum tubes. Their operation may be explained most simply by looking upon them as amplifiers of the carrier current, the amplifying efficiency being controlled by the signal wave. We are, however, concerned more with what such devices do than with how they do it.

The functional duty of the modulator, then, is to furnish a signal wave comprising a group of currents which bear the same relation to each

other, with respect to their relative amplitudes and to their separations on the frequency scale, as do the currents present in the signal wave originated in the direct current portion of the system. Thus we may think of modulation as the translation, on the frequency scale, of the group of currents comprising a signal wave. Such translation gives the new signal wave a location which bears the same relation to the carrier frequency that the location of the original wave bears to the zero end of the frequency scale. Similarly we may think of remodulation as the translation of this signal wave back to its normal position.

In practice it has been found that satisfactory telephonic communication may be obtained when a single side band only is transmitted. Either the upper or the lower band may be used.

In carrier telegraphy it has been found advantageous, though not necessary, to retain both the upper and the lower side bands for transmission. In this case, therefore, the modulated carrier transmitted over the line employs currents occupying twice the range, on the frequency scale, which would be required in the equivalent direct current telegraph system.

In the foregoing I have attempted to explain the character of the various currents with which the communication engineer has to deal. Since our object is to transmit a number of signal waves over a common medium, let us next consider the properties of the circuits and some of the means at our disposal which can be utilized to keep the currents employed for the various services separate.

Fortunately, the means at our disposal are rather varied, but broadly speaking they can be divided into two classes:

1. Simple devices such as transformers, condensers and choke coils, which discriminate between direct and alternating currents, depending upon the frequency of the latter.
2. Filters.

Because the operation of the devices included under the first classification is more simple than that of filters, it will perhaps be of interest to mention a few cases in which these more simple devices are employed to bring about separation at the lower end of the frequency scale.

The simplest case in communication engineering is the subscriber's telephone loop in a central energy system. In this circuit we employ low frequency alternating current for ringing the bell at the substation, direct current for energizing the transmitter, and alternating currents for talking purposes. When the subscriber's telephone is on the hook the direct current circuit is open but the bell is connected across the line in series with the condenser and the low frequency alternating ringing current flows through it when the operator's ringing key is depressed. When the subscriber takes his telephone from the hook, direct current from the central office battery energizes his transmitter to produce the alternating speech currents. In this latter case, both alternating and direct currents are flowing in the subscriber's loop at the same time. In the case of a trunk connection, the direct current is localized in the subscriber's loop and is prevented from flowing to the trunk circuit by means of repeating coils or condensers located in the central office.

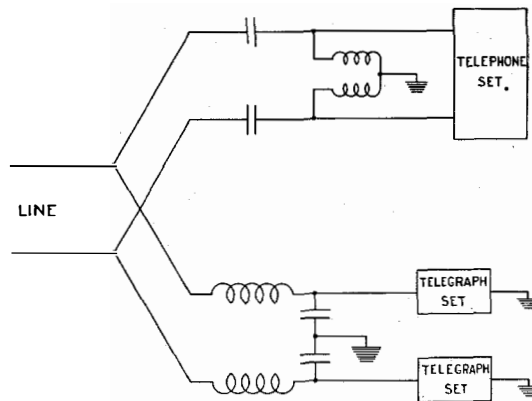

Figure 12—Diagram of An Arrangement Allowing the Use of a Line Jointly for Telephone and Telegraph Purposes

The next common example is the employment of our long distance lines jointly for telephone and telegraph purposes (Figure 12). Separate telephone and telegraph circuits are connected to the same toll line at the long distance office and utilize the same line wires in passing to the distant point. In this case, condensers are placed in the telephone branch to keep the direct current telegraph signals out of the telephone circuits, and choke coils are placed in the telegraph branch to keep the high frequency telephone

currents out of the telegraph circuits. To prevent a disturbing click in the telephone circuits when the telegraph key is operated, inductances are employed in the telegraph connection to convert the square-topped wave to one of more rounded contour.

Currents of different frequencies are also employed simultaneously on the same line when the operator rings the distant station over lines used jointly for telephone and telegraph purposes. In this case we must not pass the ordinary 16 cycle ringing current over the line because this frequency is so close to that of the telegraph impulses that the ringing current would operate the Morse relays. We have, therefore, to convert our 16 cycle current to 135 cycle current, this frequency being so much higher than that employed for telegraph operation that the armatures of the telegraph relays do not respond to it. The incoming ringing signal is received at the distant end by means of a tuned relay, the reed armature of which responds to the 135 cycle current but is unaffected by telegraph currents or talking currents.

It will be seen that in the few simple cases I have described, frequency is the keynote of separation. We utilize the selective action of condensers and repeating coils to pass alternating currents and block direct currents, and the reactive effects of inductances or choke coils to impede the passage of high frequency currents while permitting the flow of currents of low or zero frequency. The features of mechanical resonance and the inertia of moving parts to high frequency alternating impulses are also employed in the case of telephone signaling over wires used for telephone and telegraph purposes.

With these simple illustrations of current separation at the lower end of the frequency range, we will pass now to a consideration of the more complex side of the subject and describe the operation of filter devices.

The selective response of a resonant system to a particular frequency is one of the most familiar phenomena in nature. Every child who has a swing knows that he may, by properly applying impulses, each of very slight force, in time attain a considerable amplitude of motion. Although the child does not realize it, "properly" means that the frequency with

which he applies the impulses is the same as the natural frequency of the swing. The child further knows that it takes an appreciable time to build up his motion to a satisfying amplitude and that the motion will persist, with diminishing amplitude, long after he has ceased to supply energy.

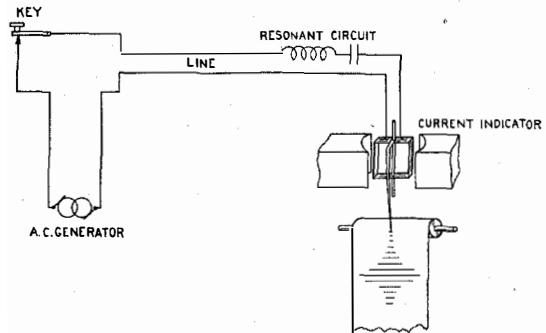

Figure 13—Diagram Showing Effect of Capacity and Inductance Upon the Transmission of Current of Various Frequencies

Electrical circuits behave in exactly the same way. Suppose that a highly resonant circuit be introduced into our alternating current telegraph system (Figure 13). Let us keep the key depressed, closing the circuit, and see how the amplitude of the current in the receiver varies as we change the frequency of the supplied alternating current. We can do this by moving the paper tape each time we change the frequency, taking care that the length moved is in each case proportional to the change in frequency. From an

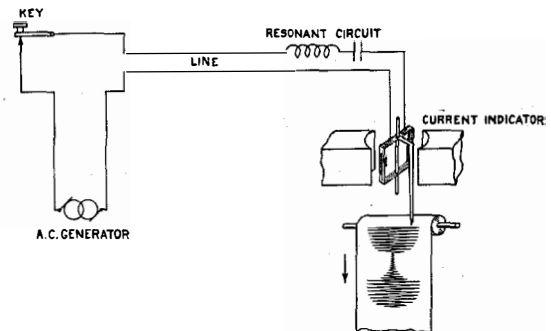

Figure 14—Diagram Showing Distorted Form of Carrier-Current Telegraph Signal Received Over System Containing Capacity and Inductance Resonant at the Carrier Frequency

inspection of the tape it is apparent that the system gives extremely efficient transmission at one particular frequency, but that this efficiency falls off rapidly as we go to frequencies greater or less than this. Now let us readjust the

frequency (Figure 14) of the generator to this particular frequency which is transmitted better than all others and again operate the key at regular intervals, at the same time moving the tape at a uniform velocity, as in our earlier

not be transmitted through the resonant circuit with equal efficiency, but that their relative amplitudes will be altered as shown by the lower diagram.

Although a highly resonant circuit transmits

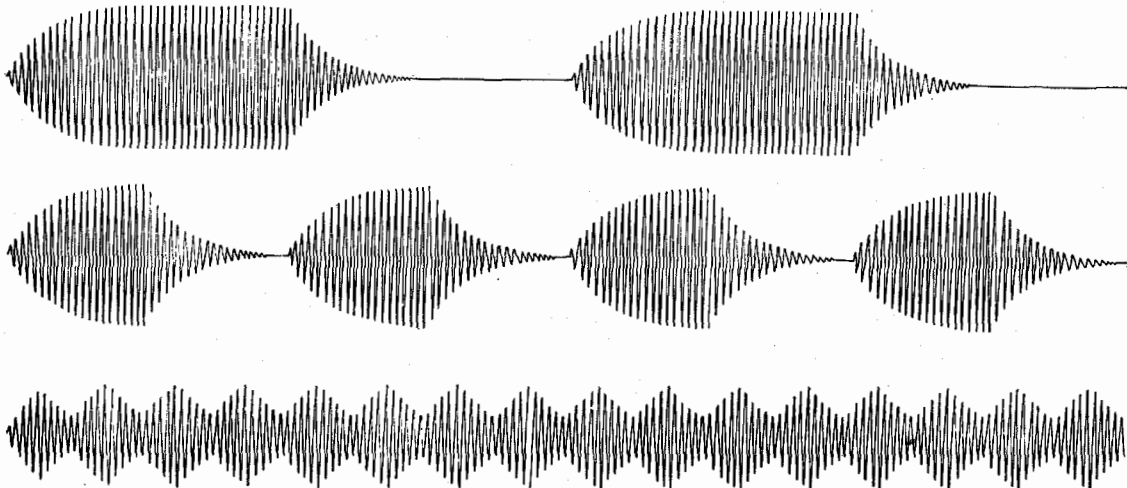

Figure 15—Distorted Forms of Carrier-Current Telegraph Waves Received Over System With Capacity and Inductance in the Line When the Key is Operated at Different Speeds

experiments. We now obtain a trace which differs appreciably from that given before the resonant circuit was introduced. Typical tapes for various speeds of sending are shown here (Figure 15). Due to the presence of the resonant circuit the current is unable to attain its full amplitude until some time after the key has been closed nor does it drop to zero until some time after the circuit has been opened. It is apparent that the more rapidly the key is operated the greater becomes the distortion of the signal wave.

This behavior of the resonant system is in strict accordance with what our experience in daily life would lead us to expect. It is of interest, however, to analyze these characteristics in terms of our complex current wave. In Figure 16 the upper curve indicates the relative amplitudes of currents of various frequencies which are transmitted through a typical resonant circuit as alternating potentials of varying frequency but constant amplitudes are impressed upon it. The next diagram is our familiar group of currents composing a square-topped modulated carrier wave. It is at once apparent that the various currents constituting this wave will

a given carrier frequency much better than other carrier frequencies, thus permitting us to select one from another, it has the disadvantage, which

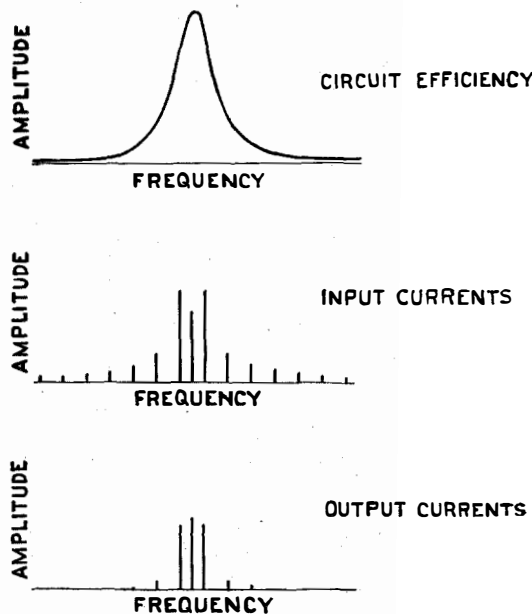

Figure 16—Chart Showing Response of a System Resonant to Various Frequencies and the Effect of Such a System Upon the Composition of a Carrier-Current Telegraph Wave

we have just considered, of preventing the amplitude of this carrier current from varying in strict accordance with our impressed signal. Our analysis has shown that we may state this difficulty in other words by saying that the resonant circuit does not transmit the several components comprising the signal wave with equal efficiency. What we need, therefore, is obviously a circuit which does transmit the several current components of a given signal with equal efficiency, or which permits the amplitude of the carrier current to be varied in accordance with the impressed signal. These two statements refer to a single property of the system.

If we attempt to increase the range of frequencies transmitted by decreasing the resonant properties of the circuit it is possible to improve the quality of the transmission, but only at a sacrifice in the discrimination against currents belonging to other signals. It has been found possible, however, to devise combinations of reactance elements which, when properly associated with a transmission system, conduct currents of certain frequencies with high and practically uniform efficiency but which restrict the flow of currents of all other frequencies. Such complex networks are known as filters.

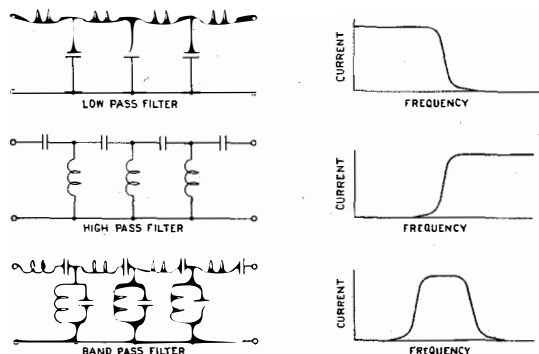

Figure 17—Typical Filter Circuits and Their Transmission Characteristics

Typical filters, together with their transmission characteristics, are shown in Figure 17. At the top of the figure is a low pass filter. Such a filter offers considerable attenuation to frequencies above a certain critical value but transmits all frequencies below this value with

little loss. The next circuit shows one form of structure constituting a high pass filter. The third circuit is that of a band pass filter. This latter circuit transmits frequencies in a certain specified range but restricts the transmission of frequencies above and below this range. Such a filter differs in performance from a simple resonant circuit in that it has a constant transmission efficiency over a considerable frequency range and has an attenuation outside of this range which may be considerably in excess of that obtainable with a single resonant circuit (Figure 18). Comparative curves of a band pass filter and of a resonant circuit are shown in this figure.

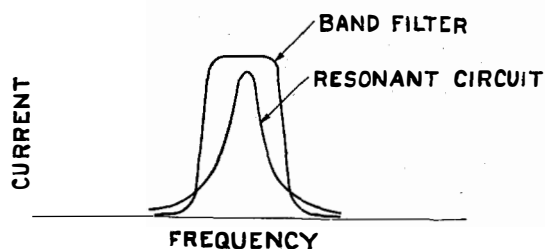

Figure 18—Comparative Transmission Characteristics of a Band Pass Filter and a Simple Resonant Circuit

In addition to this property of selectively transmitting certain frequencies, the characteristic impedance of filters is of considerable importance. Two band pass filters are shown in Figure 19. Due to the arrangement of its terminating elements, the filter shown at the top of the diagram has a very high impedance to frequencies other than those which it transmits readily. A number of such filters may, therefore, be connected in parallel since any one filter will not absorb energy associated with frequencies which are transmitted by other filters. The filter shown at the bottom of the figure, however, is so terminated that it has practically negligible impedance to frequencies other than those in its transmitted region. Such filters may be connected in series.

Because of these properties of filter networks, it is possible for us to associate a number of carrier current modulators with a single line in such fashion that energy delivered by one modulator is transmitted over the line without being absorbed by the other circuits connected to it. At the receiving end filters make it possi-

ble to separate the various signal waves and to impress them upon the remodulating circuits associated with their particular communication channel.

The foregoing discussion outlines, very briefly, the method by which it is possible to obtain from a given signal wave a new signal wave made up of a group of currents differing widely in frequency from those in the original wave.

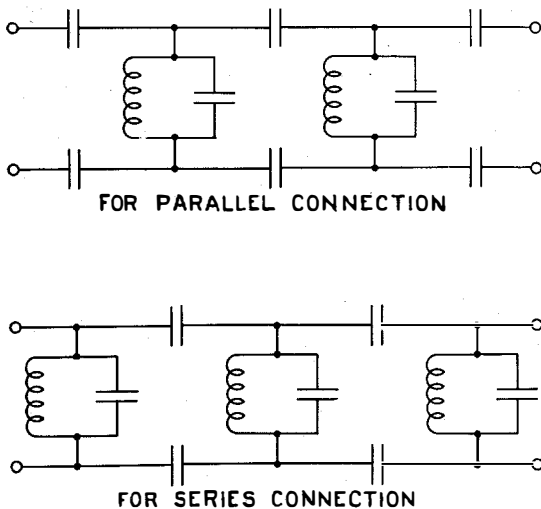

Figure 19—Diagram of Band-Filter Circuits Showing Arrangement of the Terminating Elements for Parallel Connection and for Series Connections

With respect to their relative amplitudes and to the absolute difference in frequency between them these new currents are identical with the old. Practically, then, we may move a signal wave from place to place on the frequency scale without destroying the characteristic imparted to it by the original signal.

A striking example of the utilization of this method for securing the simultaneous transmission of a number of messages over a single conducting medium is given by the multiplexing of an open wire toll telephone line.

Although such a line, as originally installed, is designed primarily for transmitting the currents required in ordinary telephony, experience has shown that it is possible to transmit currents of any frequency between zero and 35,000 cycles per second. Of course, all currents are not transmitted with equal efficiency, but by placing repeaters at intervals of 150 miles or so it is possible to equalize for any difference be-

tween the losses suffered at different frequencies. Now we have seen from the analysis of the currents present in our direct current telephone system that it is necessary to use currents between 300 and 2,800 cycles per second. The frequency range below 300 cycles may, therefore, be used for other purposes. Practically all toll telephone circuits, both open wire and cable, are used for the transmission of telegraph signals, which, as we have seen, do not require frequencies above 100 cycles per second. The method by which these two types of transmission are associated with a common line have already been described to you.

Above the frequencies required for the normal telephone message (Figure 20) there is a wide region lying from approximately 3,000 cycles to 35,000 cycles which we are free to use for such signal waves as may be employed most effectively. Because of the increased attenuation suffered by currents of high frequency and the consequent necessity for employing higher amplification in the repeaters used for the carrier channels, it has been found advantageous to employ one group of frequencies for transmission in one direction and an entirely separate group of frequencies for transmission in the opposite direction. If the entire range available for carrier transmission is to be employed for tele-

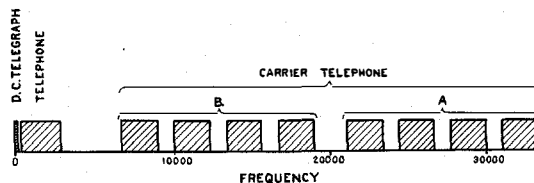

Figure 20—Assignment of Frequencies in a Representative Scheme of Carrier-Current Telephone Operation

phone channels, frequencies below 20,000 cycles are used for transmission from east to west and frequencies above 20,000 cycles for transmission from west to east. The location of the several signal waves upon the frequency scale is as shown in this diagram. Each channel is allotted a transmission range of about 2,500 cycles in width. A band of frequencies approximately 1,000 cycles wide must be allowed between channels in order that the band filters may build up sufficient discrimination against

currents associated with signal waves adjacent to those which they are designed to transmit.

This schematic (Figure 21) shows the arrangement of apparatus employed in obtaining several signal waves, each wave being characterized by the telephone message to be transmitted and by its position upon the frequency scale. The method of associating a number of such modulating, or translating, devices with a common trunk line, which is already carrying a normal

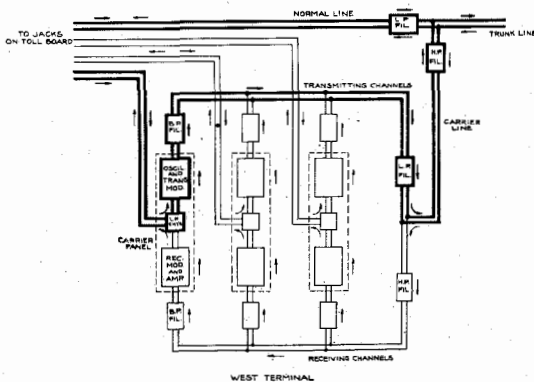

Figure 21—Diagram of the Apparatus at One Terminal of a Multiplex Carrier-Current Telephone System Showing the Arrangement of the Transmitting Circuits

telephone message, is indicated. The currents used in carrier transmission are prevented from reaching the telephone subscriber by means of a low pass filter included in the normal telephone line. Similarly, a high pass filter in the line connected to the carrier apparatus prevents the absorption of the normal telephone currents by this apparatus. The sketch shows three normal telephone lines, each associated with a jack on the toll operator's board, by which normal telephone signal currents are conducted to their respective carrier circuits. Following through the heavy line, which corresponds to a single channel, we find that it is connected first to a low frequency circuit. This circuit has the property of transmitting currents in either direction between the normal telephone line and the transmitting and receiving carrier circuits. It does, however, prohibit the transmission of currents from the receiving carrier circuit to the transmitting carrier circuit. Currents from the subscriber are, therefore, impressed upon the transmitting circuit and vary the amplitude of the carrier current in such

manner that we obtain a new signal wave, similar to the original wave except for its position upon the frequency scale. This new signal, which may be either the upper or the lower side band, is transmitted through a band pass filter, the output side of which is connected in parallel with the corresponding band pass filters of the other carrier channels. The several currents then pass through a low pass filter, designed to transmit the directional group located below 20,000 cycles, and thence to a line which transmits currents of all frequencies associated with the carrier channels, both transmitting and receiving. The function of the low pass filter is to prevent the transmitting circuits from absorbing energy which should go to the receiving circuits. From the carrier line the signal waves pass through the high pass filter which transmits all carrier frequencies on to the common trunk line.

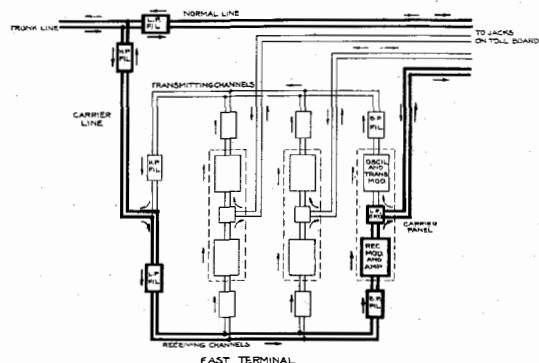

Figure 22—Diagram of the Apparatus at One Terminal of a Multiplex Carrier-Current Telephone System Showing the Arrangement of the Receiving Circuits

At the other end of the system (Figure 22) we find that the common trunk line is connected to a high pass and to a low pass filter as before. The low pass filter selects currents associated with the normal telephone and telegraph messages and conducts them to the composite set. The high pass filter selects currents used for carrier transmission and conducts them to the grouping filters which separate the transmitting and receiving currents. The currents which were sent out from the distant end of the line pass through the low pass filter and thence to the band filters which separate the several signal waves from each other and transmit them to their respective receiving modulators. The

function of the receiving modulator, as we have seen, is to restore the impressed signal wave to its normal position upon the frequency scale. We have, therefore, in the output of the receiving modulator a signal wave identical with that initiated in the direct current telephone circuit connecting to the transmitting subscriber. This normal telephone signal wave is transmitted by the low frequency balancing circuit to the line associated with a jack on the toll operators' board. It is, however, prevented from reaching the transmitting modulator by the particular arrangement of this circuit. Should it reach the modulator it would, of course, be retransmitted as a carrier wave, the location on the frequency scale in this case being determined by the frequency of the carrier current supplied to the transmitting modulator.

We have, therefore, followed through, from one toll board to the other, a particular signal and have seen how it is moved about on the frequency scale to a position which identifies it from other similar signals, how it is associated with such signals on a common line, transmitted to the distant terminal, isolated at the receiving end from these other signals and finally restored to its original position upon the frequency scale.

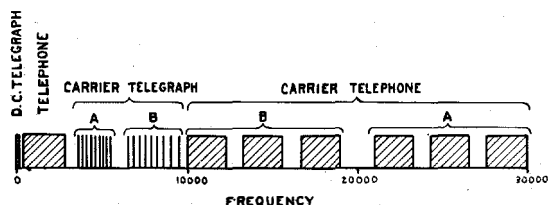

Figure 23—Assignment of Frequencies for a Line Employing Normal Telephone Channel, Direct-Current Telegraph Circuit and Carrier-Telephone and Carrier-Telegraph Channels

In some instances traffic conditions are such that additional telegraph facilities are more desirable than telephone channels. In this event one telephone channel is omitted and the frequency range thus available is used for carrier telegraph. The arrangement of channels is shown in Figure 23. As before, the entire range above 3,000 cycles is used for carrier. This range is divided into two parts, one including frequencies between 3,000 and 10,000 cycles and the other including frequencies between

10,000 and 30,000 cycles. This lower frequency group is again divided into two groups at 6,000 cycles. Frequencies below 6,000 cycles are used for transmission from west to east and frequencies above 6,000 cycles for transmission from east to west. It will be observed that the spacing between the telegraph channels is not uniform but increases with increasing frequency. This is because the particular type of selective circuit used requires a fixed percentage interval on the frequency scale to attain the necessary discrimination against currents associated with adjacent channels.

Figure 24 shows the complete arrangement of selective circuits used in multiplexing a single pair of wires with these various channels. The facilities provided are:

- 2 full duplex normal telegraph channels
- 1 normal telephone channel
- 10 full duplex carrier telegraph channels
- 3 carrier telephone channels

As far as the carrier facilities are concerned it would be entirely possible to transmit six telephone messages simultaneously, three being transmitted in each direction. The normal telephone channel will, of course, transmit in both directions but not at the same time. The total capacity of the line is, therefore, 24 one-way telegraph messages and 7 one-way telephone messages.

The figure also shows the manner in which the several groups of currents are separated for amplification at a repeater point. Since currents of low frequency are attenuated less than those of higher frequency it is sometimes necessary to put in repeaters for the carrier currents at points where they are not needed for the normal signals. Such a repeater station is shown in the sketch. The normal currents are separated from the carrier currents by means of high pass and low pass filters and are conducted around the repeaters by a separate pair of wires. The group of currents used from the carrier telephone is similarly separated from the group used for the carrier telegraph and each amplified in its own repeater. The two directional groups, both telephone and telegraph, are separated from each other at the repeater exactly as at a terminal. It is to be noted that, in the case of carrier transmissions, the currents

constituting a number of individual messages are all amplified in one vacuum tube circuit.

The numbers (6, 9, 29 and 65) shown on the triangles representing the different amplifiers indicate the necessary power amplification which must be provided in order that the signals, as they are delivered to the line, may be restored to the amplitude which they had at the beginning of the 150 mile section of line through which they were transmitted before reaching the repeater station. The considerable difference between the amounts of amplification re-

covered by a simple resonant circuit is sufficient to include all frequencies associated with even the highest quality telephone signals. The use of filters is, therefore, not necessary. It will be recalled that the absolute range of frequencies occupied by a given signal wave is unchanged as it is translated from one position to another on the frequency scale. On the other hand, selective circuits require, in general, a fixed percentage interval in which to build up a sufficient barrier to unwanted currents. Thus we see that as we go to very high frequencies more of the space is

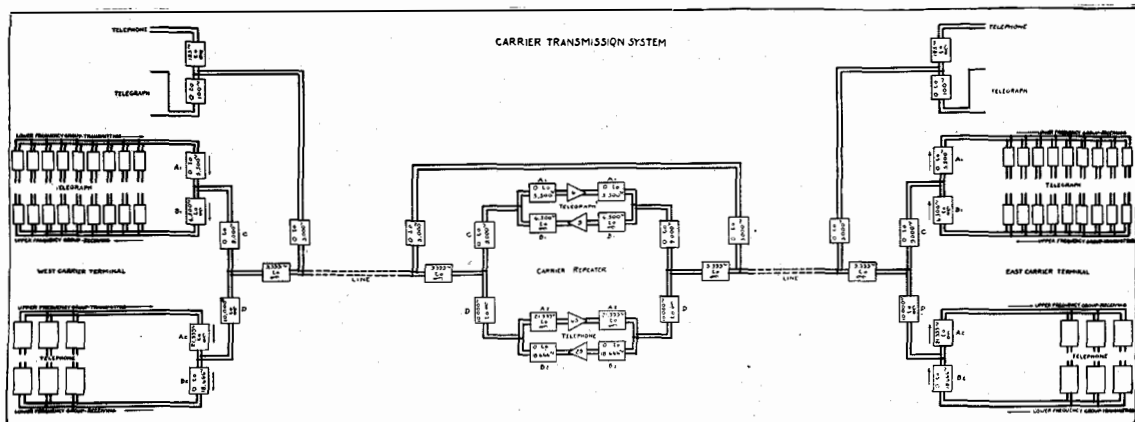

Figure 24—Diagram of the Complete Arrangement of Selective Circuits Used in Multiplexing a Single Pair of Wires for Numerous Channels

quired is due to the fact, already mentioned, that currents of high frequency are more rapidly attenuated, with increasing length of line, than those of lower frequency.

The multiplexing of an open wire line has been described in some detail because it is such a complete example of the utilization of the principle of signal wave translation. The method is, however, employed with other types of media which are capable of transmitting electrical energy. A case of considerable importance is that of radio. Here, between frequencies of 10,000 cycles and 30,000,000 cycles we have a medium which may be used for the transmission of electrical energy in the form of radiation. The means for obtaining signal waves suitable for transmission by such a medium does not differ fundamentally from those employed in the modulation of an alternating current for transmission over a wire circuit. At the very high frequencies employed in radio the range

required for the selective circuits and less for the signal waves.

More efficient use may be made of this high frequency region by what is known as double modulation. An example of this is given by the so-called voice frequency carrier telegraph. Here a group of ten or so carrier telegraph signals are located in the frequency range between 400 and 6,000 cycles. These signals are separated by intervals of approximately 20 per cent of the mean frequency of the interval. The group of currents constituting these ten signal waves is now used to modulate a radio carrier of 1,000,000 cycles. In other words, the entire group is moved bodily to a new position on the frequency scale. The absolute interval between the separate signal waves remains unchanged but the percentage separation has been reduced to less than 0.02 per cent, or to about 1/1,000 of its former value. No known circuit would possibly separate such signal waves from each

other. At the receiving end, however, the signals are selected as a group from such other radio signals as may be acting on the receiving antenna. They are then restored to their original position on the frequency scale by remodulation, or, as the radio people say, by detection. It is now very easy to effect the desired separation and so, by a second remodulation, applied this

electromagnetic waves. If this chart had been drawn to a uniform frequency scale of one inch for each 100 cycles it would be so long that it would take two and one-half years for a flash of light, travelling at a velocity of 186,000 miles per second, to go from one end to the other. It has, consequently, been drawn to a continuously varying scale such that frequencies

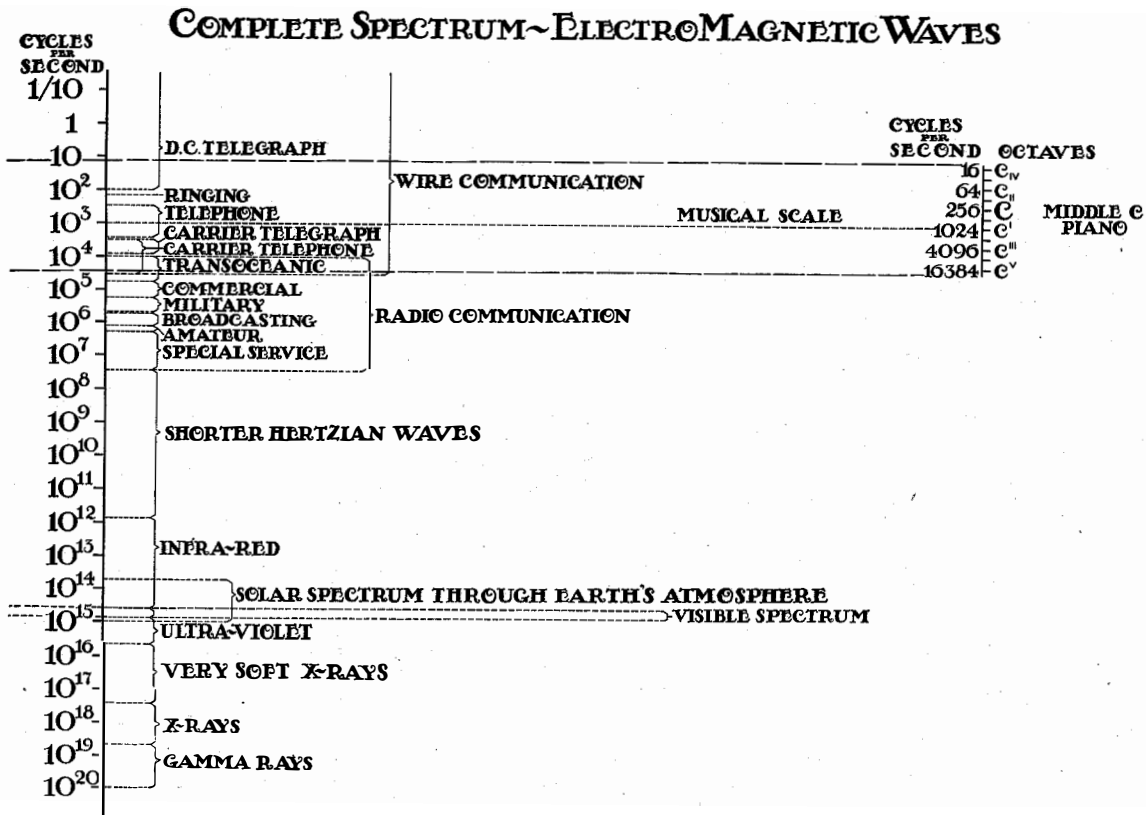

Figure 25—Complete Spectrum, Electromagnetic Waves Showing the Relation of Frequencies of Waves Used in Electrical Communication to the Frequencies of Other Waves of Importance in Daily Life

time to the individual signals, to recover the several original telegraph signal waves. By this means the message capacity of a given radio channel may be increased more than tenfold. It seems certain that very extensive use will be made of this method in the near future.

To give a bird's-eye view of the relation of the frequencies used in electrical communication to the frequencies of other waves which are, in one way or another, of importance in our daily life, a chart (Figure 25) has been prepared which shows the entire range of what is known as

corresponding to the ends of a given interval of length bear a fixed ratio to each other, regardless of the location of the interval. That is, the same space has been given to the range between 1 cycle and 10 cycles as to that between 1,000,000 and 10,000,000 cycles. On such a scale it is interesting to compare the extent of the range used in electrical communication with, for example, the range of frequencies which can be detected by our ears, the range which can be detected by our eyes or the range over which the earth receives energy from the sun.

European International Telephony¹

Progress Summarized—Some Suggestions for Business Organization— The Problems for Solution

By F. GILL

European Chief Engineer, International Western Electric Company

IN November, 1922,² it was pointed out that in Europe, considered telephonically as a whole, there were:

(a) About 40 self-contained local operating organizations, each, in the majority of cases, conducting a local business and a through business within its area, also that part of the international through business which lies within its own borders.

(b) No organization controlling or co-ordinating the various local operating organizations, which yet have to function as a whole.

(c) No means of keeping the separate organizations in touch with each other, and no systematic means of adjusting differences in matters of daily practice.

(d) No organization of any kind which handles and cares for the through business as a whole.

(e) No common agreement as to manufacture.

(f) No common research, standard practice or technique of construction, maintenance and operation.

SUGGESTED IMPROVEMENTS

The following suggestions were made at that time:

1. To operate all the through business both within and between the various countries in Europe by a single long-lines company working under licenses from the various Governments, taking the calls from the local originating organizations, and being entirely responsible for them until turned over to the local receiving organization.

2. The various Governments to form what would in effect be a Commission, of which only Governments would be stockholders, to carry on the International Telephone Service.

¹ Reprinted, by permission, from *The Electrician*, Vol. XCII, April 25, 1924.

² Inst. of El. Engineers—Presidential Address, Vol. LXI, p. 12; *The Electrician*, Vol. LXXXIX, p. 534, Nov. 10, 1922; *Electrical Communication*, Vol. I, No. 2, Nov., 1922.

3. The third alternative was frankly one of a temporizing nature, being intended only to cover a study of this difficult problem. It was that the various operating telephone authorities should form themselves into an association for the purpose of studying this and other matters. Such association might come about gradually if necessary, and regular meetings might be fixed for the purpose of studying a pre-arranged programme, which, *apart from the larger question as to how the through business should be operated*, might include the fixing of standards of measurement, performance and methods to be recommended to all, and to be enforceable on those subscribing to the association. The author was convinced that unity of direction over the through traffic must obtain in the end, but whether the through traffic were to be handled by one organization or by many, there were matters which urgently required agreement.

Following these suggestions, an International Conference at which Belgium, England, France, Italy, Spain and Switzerland were represented, was called³ by M. Paul Laffont, at Paris, to consider from the technical point of view the complex question of telephony over great distances in Europe. At this Conference the first suggestion, viz., to operate all the telephone through business by means of one long-lines company for the whole of Europe, was not agreed to. Suggestion No. 2, by which the Governments would form a Commission for the operation of the long lines, did not apparently receive much consideration. Suggestion No. 3, which visualized a plan of study, and was not put forward, as were suggestions 1 and 2, as a solution of the problem, was adopted, and at that international meeting there were inaugurated a permanent office and a permanent advisory international technical committee for international

³ Comité Technique Préliminaire pour la téléphonie à grande distance en Europe. Paris: Mars 12-20, 1923.

telephone communication. Much good work was achieved at the 1923 Conference, especially in getting the unanimous approval of the delegates of the six nations present to many important technical proposals, and so well was this done that shortly after the close of the Conference all the recommendations were officially confirmed by the Ministries of these nations.⁴ Another International Technical Conference is to be held in Paris in April, 1924, and the general interest in this matter is indicated by the fact that all the European telephone authorities have been invited, not only the six nations of the first Conference, and that there will be a large attendance. This is a high tribute to the work of the Preliminary Technical Committee, but most unfortunately it has in the meantime suffered the loss by death of its able president, M. A. Dennery.

The larger question as to the organization by which the through business should be operated does not appear, so far, to have received much attention, and this present article is intended to expand the suggestion No. 2, which concerns the business organization, not the technical aspect of the subject.

It is perhaps not always clear why it is necessary to have unity of direction in the form of a permanently operating authority and not one which is advisory or consultative. If the subject is considered in several aspects this need will be appreciated.

The business to be handled is a rapidly growing one; some things are known, but much is not yet known; traffic routes are very undeveloped; some organization, not too unwieldy, must take decisions regarding the commercial risks involved in the construction of new lines, the facilities required by the public, the rates to be charged for their use, the routes to be followed, the specifications for the plant, the circuit layouts.

The same reasons, all of which require the power of quick impartial decisions, apply also to many aspects of working when once the lines have been constructed. In the regular testing, in the maintenance, in the substitution of good lines for faulty ones, in the repair of damaged

lines and apparatus, there is no room for divided counsels or for slowness in decision.

NECESSITY FOR UNITY OF DIRECTION

In the quick diversion of facilities to meet sudden unforeseen demands of traffic, in the replies to inquiries for new facilities, in the operating technique, in the operating schedules and in all that appertains to the exploitation are found conditions which cannot be met by any organization except one in which the general direction is unified, and this largely because causes which are local may, and often will, produce effects which are not local but general.

It has been recognized practically in the past that it is a difficult and very slow affair to get new lines constructed between two contiguous countries, involving meetings, discussions, sanction by parliaments; and it has been recognized as an almost impossible task to get new lines constructed between non-contiguous countries and through one or more non-interested countries; to these reasons, rather than to great distance, is due the fact that in Europe there is so small an international traffic and practically no traffic at all between countries whose boundaries are not adjacent.

The telephone business differs from some other businesses, and particularly from through railway work, in this: in telephony it is necessary that the whole of the machinery and wires involved in a connection between any two subscribers shall be in operation simultaneously throughout the entire length during the progress of the conversation. For example, if a call is made from London to Christiania, the whole line, passing through, say, England, Belgium, Germany, Sweden and Norway, will be entirely occupied for the time by this one call, and must operate as one unit, without regard to the different ownerships through which it passes. The various kinds of plant must be harmonious, the methods of operation must be similar, and when repairs have to be made, or changes effected in the circuits, such matters must be attended to promptly; and, generally, there must be unity of direction (not merely of advice) over the fundamental matters, while large authorities are delegated to the local organizations.

The case of international railways is alto-

⁴ *Annales des Postes, Télégraphes et Téléphones*, Sept., 1923; *Electrical Communication*, Vol. I, No. 2, Oct., 1923.

gether different; that business is somewhat in the nature of the transmission of a parcel or package from place to place, and from hand to hand. When rolling stock is sent from Paris to Constantinople, the length of line engaged by that rolling stock at any one time is strictly limited, and the whole line has never under any circumstances to be simultaneously and solely at the disposal of that particular rolling stock. So long as certain fundamentals, such as the gauges, time tables, etc., are preserved, many other things may differ without affecting the service. Locomotives, for example, and the signalling, may be quite different in different countries, hence the analogy of international railways does not afford much light on this telephone problem.

So far, the International Technical Committee is devising detailed rules for standard methods of construction and operation, which, while good in themselves and tending to standardization, do not lead to unity of direction; having a somewhat rigid character they may even be difficult to depart from in particular cases, and it is probable that some European international lines may have to be constructed without conforming to the rigid rules laid down for the general system. Further, it seems somewhat unlikely that any modern rules can be applied to the utilization of such existing international lines as are available or can be built up out of the existing networks.

One of the decisions reported by the International Committee in March, 1923, involved the recognition that the financial and executive control of the international telephone system in each country is to remain in the hands of the Minister responsible before Parliament. It is not clear whether the Technical Committee took this principle as a necessary basis on which they must work, or whether it was a recommendation from the Committee; possibly this was a subject on which the Technical Committee would not express an opinion. But this statement as to the continuance of the responsibility of the Minister does not in any way militate against the consideration of alternative No. 2.

In all large organizations delegation of authority is necessary and is practised. In the present local telephone systems, while the

Minister is responsible to Parliament, large measures of authority are delegated to officials, and there appears to be no reason whatever why sufficient authority should not be delegated to a body of officials allocated to carry out for Europe as a whole that service which no one country can carry out efficiently for itself, which cannot be carried out as it should be without securing in some form the necessary degree of unity of direction.

PROPOSED PLAN GIVING UNITY OF DIRECTION

The proposed organization now to be explained is that of a commission acting virtually as a private company, of which only Governments would be stockholders. Each country subscribing to the scheme would elect one or more commissioners, the number of commissioners from each country being identical. These commissioners would be chosen so as to cover all the aspects of the subject, and they would form the directorate of the organization.

In order to supply the necessary funds the capital required would be divided into two unequal parts—the working capital and the plant capital. The capital cost of setting up the system (not constructing the plant) and the subsequent carrying on of the service would be provided for by the initial working capital, subscribed equally by each country entering into the scheme, and as a tentative figure the equivalent of £10,000 from each country is suggested as the initial amount. Since it seems likely that at least twenty countries would join the system, this would give an initial working capital equal to £200,000, quite distinct and apart from the money to be expended in plant, land and buildings, called the plant capital. As and when required additional working capital would be called up, and again in equal amounts from each country.

The first duty of the commission would be to appoint the executive officers for carrying out all the planning, construction and operation of the long lines throughout Europe, to the extent that the commission would do such work. These executives might all be selected from the services of the various governments; some might, if necessary, be members of the commission, in the same way that a managing director of a

company may be a member of the board of directors and at the same time be an executive officer. An essential matter in the appointment of the executives would be that they should give to this service their whole time, exactly as they would were a company handling the business.

Working capital and executives having been secured, it would be the duty of the executives to study the needs of the traffic and make plans for handling the European traffic as a whole, without any regard whatever to politics or to the political aspirations or boundaries of any country; save only that due allowance would be made for alternative routes, so as to minimize disruption to the service in case the lines of any nation became unusable, as would be the case in war. The plans having been made, decision would be taken as to how far the plans could be carried into effect; when this had been decided the plant required to be constructed in each country could be set out, budget estimates be made, and the plans and budgets be submitted to and approved by the commission, who would pass on, to each country, the budget for approval by Parliament if necessary.

The detail plans for each country would then be forwarded to the country with the request that the work be proceeded with; the commissioner for each nation would already have studied and approved the plans, and it is not anticipated that there would be much dispute concerning the wisdom of them. Should there be any discussion, the commissioner for the country concerned would naturally be fully informed and the matter would be settled in conference; but it is felt that after a short time the views of the commission would be regarded as settling the plant required. Parliamentary sanction of expenditure having been obtained, say, for each year, or longer period, each project would not be delayed by the necessity for parliamentary investigation into it.

PLANT CONSTRUCTION

The plant required would then be constructed in the country designated; it would be constructed by the country or by the commission as agreed in each case, to the specifications of the commission and subject to verification by it.

The cost of the plant would be paid for by the country in which the plant is situated, and this cost would become that country's contribution to the plant capital; the plant would belong to that country but be turned over to the commission to maintain and operate. Special arrangement would be made regarding the construction and ownership of submarine cables outside national frontiers. There might be cases of countries unable to provide the necessary plant capital, but unwilling that such a reason should be a hindrance to the construction of the required international lines. In these cases, it seems probable that the commission could influence the raising of the money required, the plant to be constructed being accepted, perhaps, in part security for the loan, or the commission might be provided with funds and be authorized to pay for the construction of, and own such lines.

In some cases the international plant would be independent and separate; in other cases it would be part of a larger plant; thus 50 international circuits might be provided by an independent international cable, or be part of a larger cable operated by a country, or again might be part of a larger cable operated by the commission; the holder, in any case of joint use, leasing circuits to other parties. In the case of existing lines to be taken over for international traffic, they could be either valued and transferred or leased. Thus the plant arrangements could be treated in each case in the most advantageous manner.

This method, subject as above, requires each country to provide the money necessary for the construction of all the international plant within its boundaries; on this plant capital the commission would pay to the countries a uniform rent of, say, 5 per cent per annum, and the commission would be responsible for maintaining and renewing the plant (or paying for these services) and for turning over to the country the plant in good order, together with the proper depreciation fund, should the agreement ever terminate.

EXPLOITATION

The operation of the entire system thus constructed would be in the hands of the commission,

who would maintain their own repair and operating forces and generally conduct the through business for all the countries. But in the event of it not being economical for the commission itself to operate any individual portion of plant, it would arrange with the country concerned to do this for it. Thus the international traffic could always be operated and extended, even in places where the traffic was very small.

In some cases there would not be enough traffic to warrant the construction of separate international lines. In these cases the commission would arrange to borrow, as and when required, lines operated by a country, and a proper proportion of the fee received for the international call would be paid to the country for the use of its line. When the international call was to be completed over national lines a proper fee would also be paid for such accommodation, and it might even be desirable to pay the local organization a fee for the terminal facilities used in respect of each call.

The commercial side of the through business would be handled by the commission, and all matters regarding additional facilities required by the public, such as long private telephone or telegraph lines, private lines for certain specified hours only, and similar matters would be dealt with by this section of the commission's executives. The rates to be charged for long distance service (as well as the standards of service to be given) would be drafted by the executives and settled by the commission. The rates would be fixed to be reasonable from the public point of view and would be sufficient to pay all the expenses, including the rent on plant capital, provide for all proper reserves, and in addition produce a profit. This profit, so far as it was judged advisable to distribute it, would be divided among the countries in proportion to the working capital provided by each country, that is equally.

ADVANTAGES OF PLAN

Looking over the scheme thus set out, it will be seen that it provides for the responsibility of the Minister to Parliament, because he is always acting by means of his own delegates, to whom he can give instructions, and he can withdraw from participation in the commission if such a

course should unfortunately be found necessary. It retains the ownership of plant in the country in which it has been constructed and by which the money for its construction has been found; and it provides for the finance in a simple and logical manner. It retains, to any country which feels the necessity, the construction of the long distance plant in the hands of its own regular construction forces. It retains to the long distance authority—that is, to the commission—the unity of planning, direction, verification and operation without which it is impossible to carry on efficiently the through business. This matter is of paramount importance; the through business is not a simple, easy matter; it is, on the other hand, a complicated, difficult business; with a proper organization it can be made to render effective service and without such an organization the service can only be second-rate. New methods, such as long distance loaded cables, repeaters, carrier circuits and the utilization of the same circuits for both telephone and telegraph traffic have altered conditions in many ways; engineering requirements are much more severe than formerly and uniformity is essential; the increased distances now possible and the reduced costs make for great volume of traffic; the demand for flexibility to meet conditions which change daily, and at the same time the demand for absolute reliability of service over a very wide area, in various countries given by means of persons of varying races, all these call insistently for unity of direction.

The scheme provides for flexibility in planning; by reason of the unity of direction no detailed rigid rules are required. Instead, subject to general principles, each case can be dealt with individually and with the most economical treatment proper to its case; advances in the art can be availed of as they become feasible.

The scheme permits the nations on the commission to meet on equal terms. Each nation would have the same number of delegates, provide the same working capital, receive the same rate of return on the plant capital expended by it, have the same share in the control of the through service and receive the same share of the profits.

It permits the through business to be en-

visaged as one entity without regard to political hindrance; it provides a satisfactory solution for one of the present difficulties—viz. the building of lines through countries which are not interested in the traffic on the route. Lastly, it provides a means of improving the local services so far as they react on the through business; if it were found that in any case the international business was suffering injurious reaction from defective local service, the presence of the nation's representatives on the Commission would provide a ready means for the exposure and redress of these troubles. Further, since the long distance service experiences the most difficult conditions, the extension and unification of this service would be bound to affect beneficially the local services.

ALTERNATIVES

The alternatives to some such plan as sketched are: (1) To turn the matter over to a company, but this has already been rejected; and (2) to frame a detailed code of rules to be observed by each country acting in the manner it believes to be in conformity with the code, with an advisory committee reporting at intervals. Such a course cannot give an efficient service, and this procedure would be much as if, after setting up a code of rules for the operation of the various activities of a steamship, it should be decided that having these rules no captain was

now required to take the responsibility and direction.

Recently and since the above scheme was drafted, I have read, for the first time, a proposal contained in an article entitled "Long Distance Telephony in Europe," by Monsieur M. G. Martin, which appeared in the "Annales des Postes, Télégraphes et Téléphones," for June, 1921. In this article Monsieur Martin proposes (I believe for the first time) that an association be set up by the European Administrations for the purposes of construction, maintaining and operating long international telephone circuits, and he sets out his proposal in considerable detail. He states: "This system would present indisputable advantages; it would allow the exploitation of important European telephone lines to be entrusted to one single organization, commercial in form, though official in reality. It would cause all complications inherent in existing practice to disappear, would unify the methods of work, and would guarantee the development of the service according to needs, whilst reducing to a minimum all financial difficulties." Monsieur Martin's paper deserves much more attention than it has received. Had I been aware of his proposal at the time the paper would have been referred to in my presidential address to the Institution of Electrical Engineers.

Telephone Transmission Standards in Europe

By L. C. POCOCK

Engineering Department, Western Electric Company, Ltd.

TO engineers and administrators concerned with telephonic communication, the measurement of transmission values is a vitally important matter. It is only by means of measurement, direct or indirect, that telephone systems can be installed with the foreknowledge that intelligible communication will be possible, and it is again only by a process involving measurement that assurance can be given that the cost of the system is no greater than required for the accepted service standards.

The development of a telephone system naturally depends to a great extent on the cost at which communication can be afforded. The lowest cost must evidently be reached when there is no element of the system at which a small unit improvement in transmission could be more cheaply introduced than at any other taking into account the relative numbers of the various elements in the system. If there were such an element, it would be economical to introduce the improvement and to make a small reduction of the efficiency at points having a higher value of cost per unit improvement. It is, therefore, not too much to say that transmission measurements of the performance of every part concerned in actual telephonic communication are essential to the design of a system affording a desired grade of transmission, and that they are equally essential to the solution of the problem of securing this result at lowest cost.

From the early days of telephony, the necessity for a measure of the performance of telephone apparatus has been widely appreciated. As scientific progress has steadily extended the range of communication, the importance of these measurements has materially increased in direct relation to the number of instruments in use and to the amount of invested capital. The result is that, at the present time, telephone administrations which have not before studied transmission matters are compelled to do so by the development of their system and

by the necessity for linking up with other and larger systems. Other factors too move in the same direction: the growth of commerce, and of every phase of civilization, calls ever more insistently for efficient and rapid means of communication over distances as little confined by frontiers as are the necessities of mankind.

Thus telephony has become international. There is in essence, as there must some day be in fact, one corporate telephone system in Europe, and all the administrators of this great network of communication have one common purpose, for the proper carrying out of which there must be unity in method and agreement upon definitions. Before all, there must be uniformity in the definition of transmission data and agreement upon the fundamental basis of measurement.

It would be unhesitatingly conceded that the world-wide adoption of a common system of transmission measurement would be preferable to the use of different local systems; just as it is agreed in principle that the adoption of the metre as a unit of length by Britain and Russia would be more convenient than the use of the yard and the arsheen. In the case of measures of weight and length, however, accurate comparison between different units is possible and several elaborately equipped laboratories exist where these comparisons can be made. Transmission measurements are in a different category. There is available at present no simple, suitable means of measuring the received intensity of speech sound, except by the sensation it produces, and comparisons by this means have relatively low precision. There may be suitable laboratories where different standards of transmission might be compared; but extensive investigation has shown that there is not always a definite relation between independent standards because the comparison depends upon a large number of parameters and yields a different result according to the conditions under which the test is made. An

analogy and a contrast are seen in the corrections for temperature in comparing physical standards of length only in work of the highest accuracy. The effects of the conditions under which transmission measurements are made are of extreme importance in all cases and must, therefore, be very fully specified.

If different transmission standards are not capable of precise comparison and correlation, sound and economic design of the transmission system connecting two countries where different standards are in use is not possible. A further disadvantage of having independent standards, a disadvantage more serious than the inconvenient diversity of practice in weights and measures, is the inapplicability of the technical literature and published research of one administration to the problems of others.

To appreciate the arguments against the use by each politically independent community of its own local standard system, it is necessary to have a clear idea of what transmission standards are and how they are used. For a telephone conversation to be intelligible, it is essential that the volume of sound received by each subscriber shall be sufficient to be easily audible in spite of any reasonable amount of noise. It is necessary in any connection that there should be a measure of the received speech-volume, and that this measure should yield information regarding the satisfactoriness of the connection by comparison with known constant conditions. Since for this purpose direct measurement of the speech-volume received by the ear is not practicable, it is natural to make measurements by comparison with a physical standard; i.e., by comparison with a carefully defined but arbitrary telephone connection, which may be called a "reference circuit." Thus a base line is obtained, and a given telephone connection can be said to deliver speech that is louder or weaker than the speech heard on the "reference circuit."

The next requirement is a scale of units permitting the use of a numerical expression to indicate the amount by which speech received on the given circuit is better or worse than that on the reference circuit. Since telephony has to do with communication at a distance, it is natural to apply a scale to the "reference circuit" by altering the line-length between its

end-stations. Then the speech-volume received over the given system can be defined by a statement of the distance apart that the stations of the reference circuit would have to be in order to give the same volume of received speech.

So far, a perfectly general principle of measurement has been enunciated. It is in the details of definition of a reference circuit that there

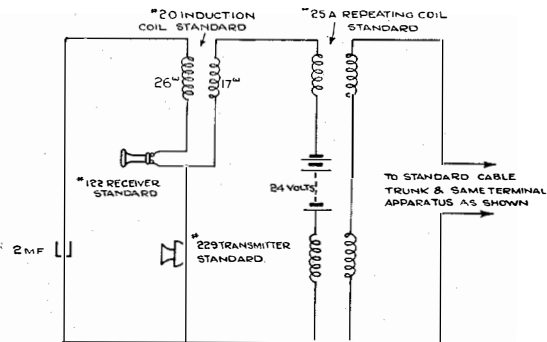

Figure 1—Standard Reference Circuit. (Bell System)

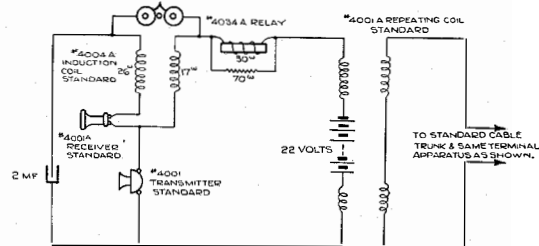

Figure 2—British Post Office Reference Circuit. The British post office test circuit is the same with 300ω resistance inserted in the local loop. The transmission apparatus used is closely equivalent to the apparatus in Figure 1, except that the receiver here is equivalent to a No. 144 receiver, and the transmitter and receiver standards differ in efficiency

is not perfect accord, and it is, therefore, desirable to see what the essential details are and how they may be best defined.

A reference circuit must consist of a transmitting station, a receiving station and a connecting line, the variation of which ordinarily provides the scale. The terminal stations of the reference circuit may be, conveniently, the same at each end, and a standard type of common battery substation has been adopted. Differences in definition, however, occur as may be seen by a comparison of Figures 1 and 2, which show the reference circuit used by the Bell System of America and the reference

circuit used by the British Post Office and some other Administrations. These discrepancies are of such a character that exact allowance can be made for them; and the relationship between the two circuits could be established but for the differences between the standardized transmitters and receivers, which must now be considered.

From the transmission point of view, transmitters and receivers are machines for modifying energy; and their performance as such varies widely with the conditions under which they are used. In the selection of a standard, therefore, it is necessary to state the condition under which the standard performance is obtained; and, in the reproduction of the same standard, the same performance must be obtained under the same conditions. Furthermore, it does not follow that because two sets of standards bear a certain relation to each other under one set of conditions, they will have a similar relation if the conditions are changed. Hence, in order that the physical standards may have the widest possible application, they ought all to give, as nearly as possible, the same performance under certain specified conditions.

The reference circuits shown in Figures 1 and 2 do not provide suitable conditions for testing the equality of transmitter standards because the battery current is rather large and renders transmitters of the ordinary type unstable and uncertain in their performance. It is, therefore, the custom to make the comparison in some other circuit, which may be regarded as a standardized test circuit. The test circuit and the testing technique constitute the set of conditions that must be specified in connection with the Transmitter Standard. Having secured a number of transmitters, which all give the same performance in the test circuit, they constitute a Transmitter Standard, which may be supposed to give a definite average performance in the reference circuit, calculable from suitable data or determinable experimentally.

Existing practice in countries where transmission measurements are made follows one of three systems, which may now be examined in turn. The reference circuit, the essentials of which have been described above, owes

its existence to the necessity for using physical apparatus as a standard of performance for the energy changes effected by transmitters and receivers. Such transmission measurements as do not involve transmitters and receivers do not require a reference circuit as basis, but may be fully expressed by a statement of electrical transmission efficiency.

Either because telephone administrations in some countries have, until recently, regarded the substation apparatus as the property of the subscriber and have not been concerned with its efficiency, or because in other countries the transmission problems associated with the lines have received special consideration, there are a number of Administrations who do not use a fully defined reference system and who restrict their transmission studies almost entirely to the electrical losses between the transmitting subset and the receiving subset. Under such conditions it was natural that βl , which occurs in the well known line transmission formulæ, should have been adopted as the measure of the transmission efficiency of the line. The use of βl has been extended to express the efficiency of transformers and other apparatus, purely electrical in function; but, with the methods of measurement at present available, it is not convenient to express the efficiency of transmitters and receivers in βl units because the efficiency of these instruments depends upon acoustic as well as upon mechanical and electrical phenomena. The *relative* efficiencies of a number of transmitters or receivers can be expressed in βl units, and therefore the overall efficiency of a system can be expressed in terms of βl units and of a reference circuit using standardized instruments; but without standardized instruments, no such statement of overall efficiency is possible.

The principal criticism of the βl system is that it is, based exclusively on line-formulæ, and that it is applied only by an extension of ideas to the other apparatus; it is, however, logical and scientific, and if the reference standards are fully and completely specified, together with their conditions of use, it fulfills the essential requirements of a transmission measuring system. In many actual cases this system appears to be used without fully defined reference instruments. This omis-

sion renders a comparison with other measuring systems impossible, or more than ordinarily uncertain.

The second system of measurement in common use is that of the British Post Office and some other Administrations. Both reference circuit and instrument standards exist, and there is a defined test circuit and testing technique. The standards are unsatisfactory only in one small respect that has already been referred to; i.e., they are physically represented by instruments related by allowances or corrections to an efficiency value that is not attained by instruments of their nominal type. The test circuit is well defined, but includes a considerable length of standard cable which, by its high attenuation of the upper frequencies, causes the circuit to discriminate against transmitters and receivers of better speech quality than the standards. Some consideration must also be given to the fact that there is no organization to ensure that the technique of testing adopted by the users of this system is uniform, nor is there a firmly organized routine of periodic comparison of the instrument standards used by different Administrations.

The third system of transmission measurements has been in use by the Bell System from the early days of telephony, and has become highly developed in respect both of testing technique and organization. A reference circuit, the parent of the British reference circuit, is fully defined and used as the basis for all statements of transmission efficiency. Basic instrument standards of the types used in the reference circuit, and other secondary standards of all types commercially manufactured, are prepared and calibrated on a suitable test circuit approximately representative of common service conditions, using very carefully specified testing technique.

In order to cater for the requirements of manufacture, maintenance and repair of the 13,380,000 telephones of the Bell System in the United States of America, a very large number of substandard instruments are required (of one type alone there are over 800), and careful organization has been necessary to provide a continuous supply of standards and to ensure their regular periodic checking.

This system has been in use in the Bell System Research Laboratories for some years, and it has been recently strengthened in Europe by the provision of organization to keep the standards and testing technique uniform and in agreement with the standards and testing practice of the United States.

Of the three transmission measuring systems that have been described, it seems inevitable that, if technical literature from every source on communication problems is to be uniformly interpreted by all readers, and if interstate telephony and radio telephony are to be administered on an economical basis, only one can survive. It is, therefore, desirable to examine the relative merits of the three systems and the extent of their use. Taking the second consideration first, the following table has been prepared showing the approximate number of telephones in use by the Administrations using each system. In arriving at a decision upon standard methods, the magnitude of these figures must necessarily be taken into account.

TOTAL TELEPHONES OWNED BY ADMINISTRATIONS
ADOPTING, OR LIKELY TO ADOPT, VARIOUS
METHODS OF MEASUREMENTS

| | |
|---|------------|
| <i>β</i> l System of Measurement..... | 3,035,978 |
| British System of Measurement..... | 1,945,280 |
| Bell Telephone System and Independent Companies which must use the same standards ultimately (U. S. A. and Canada)..... | 14,777,273 |
| Administrations in Europe having no system of measurement..... | 542,774 |
| Other administrations of the world probably having no system of measurement..... | 1,647,655 |
| Total world's telephones..... | 21,948,960 |

Turning now to the relative merits of the three systems, it appears that the *β*l system, though scientifically sound as a means of measurement, does not include definite transmitter and receiver standards recognized by all who employ the system. It has, therefore, no recognized standard of overall transmission efficiency to offer as a World standard. It is the establishing of such universal instrument standards, and the method of using them, that must first be gained; the method of expressing the results is a later consideration. In comparing the British and Bell Systems, it is seen that both have standards to offer and both express results in miles of standard cable, but the standards differ and the

methods of using them differ. The choice between these two systems might well be made on the basis of the numbers shown above, but more important even than the number of stations in use is the number of calibrated instruments that can be linked together by periodic tests to ensure invariability of the world standard. Organization actually exists which maintains duplicates, in Europe, of the American transmitter and receiver standards, and is ready to distribute exact substandards to all who desire to use them. The scheme for the provision, distribution and maintenance of standards has been established through the agency of the International Western Electric Company.

So far existing transmission measuring methods have been compared with the object of determining which method was best able to furnish a reliable and definite base line or scale zero from which to make measurements; this, in international telephony, is a factor of the utmost importance because, being specified by physical models, differently defined scale zeros are not always simply related.

A matter of considerable convenience but less fundamental importance is the adoption by all Administrations of the same scale or unit of measurement; agreement upon the unit of measurement is less important than the adoption of a common zero because the unit does not depend for its existence upon a physical model, nor is it difficult to specify precisely the technique or conditions under which it must be used.

Now, although the present methods used in transmission measurement are not irreproachable, they must, for reasons of urgency, be adopted in laying down the plans for international communication, and therefore the scale zero, or reference circuits already in use have been discussed. It is, however, appropriate to examine also the failings of the existing methods and the possibility of introducing something better and, with this inquiry, the choice of a new transmission unit may be conveniently coupled, for, as will appear, the units now in use are neither universal nor ideal.

The indictment against all existing systems of measurement may be stated in the following terms:

(1) The terminal instrument efficiencies cannot be expressed in absolute units, but have to be represented by physical models known to be somewhat variable and dependent upon the technique of use.

(2) The unit of measurement is an arbitrary unit variable with frequency (standard cable).

(3) Reference circuits in the forms adopted are used as scales for measuring loudness only, although the distortion also varies with the length. Further, the reference circuits in use contain considerably more distortion than good modern telephone circuits.

In contrast, the requirements of a measuring system that would approach the ideal may be drawn up under the following headings:

(1) The whole system of measurement should be prepared with a view to measuring ultimately the intelligibility of telephone connections and not merely the loudness, but it must be possible to give data for separate parts of a circuit which can be simply used to express the telephonic efficiency (intelligibility) when two or more such parts operate together.

(2) Transmitter and receiver standards should be capable of calibration in absolute units and should be, as far as possible, independent of the technique employed in using them.

(3) The transmitter and receiver standards should be used in a defined variable circuit, forming a reference circuit for loudness efficiency, and such a circuit should be a scale of loudness only, with fixed distortion, or preferably none.

(4) The unit of measurement should be a power unit, logarithmic in character and independent of frequency.

The requirements that have been laid down go so far beyond present practice in transmission matters that it is desirable to examine them more closely in order to establish that they are essential, and to determine how far they can be realized.

It will scarcely be disputed that the intelligibility of the communication afforded is the proper measure of the effectiveness of a transmission system, or that it is essential in transmission engineering to assign transmission values to separate parts of the system, such as the transmitter, the transmitting end, the line,

etc., in order that the performance of combinations of these may be predetermined. Extensive studies have been made to determine the factors which govern intelligibility; but the results are not yet ready for general practice application. It is clear, however, that in the future the criterion will be of this kind, and it is important that the new standard of reference should afford a suitable basis for intelligibility as well as for volume. To fulfill this requirement, it should itself be as nearly distortionless as possible.

Such a standard can be obtained by the combination of a good quality transmitter, an accurately calibrated amplifier, a receiver and a suitable corrective network. A distortionless transmitter standard of this kind can be calibrated for pure tones by means of a thermophone receiver and can, therefore, be checked independently of comparisons between a number of similar standards; it can also be calibrated to the extent of determining its average current or power output when it is excited by speech.

A transmitter standard which could be checked for constancy by absolute physical methods would be a great advance over standards at present in use; these cannot be so checked because they are subject to small changes in distortion, indicated by changes in the frequency response characteristic which may and generally will affect the apparent loudness efficiency.

By means of the calibrated distortionless transmitter standard, a carefully constructed receiver may be standardized and checked by easy measurements once it has been supplied

with a corrective network; here it is to be noted that the nature of the network required would be determined by measurements made with the transmitter standard and that this standard would itself form a valuable sound measuring device for a variety of acoustical purposes.

The application of the primary standards to the ultimate purposes of testing commercial instruments is rather outside the scope of this article, but it may be indicated that reference or primary standards represent a general standard not directly applicable to commercial use; it is the function of standardization laboratories to determine the relation of substandards of local types to the primary standard under representative conditions of use. Such determinations would represent average effective values, as the comparison would be rendered difficult by the difference in tone quality between commercial instruments and the distortionless standard, but this difficulty would be encountered with any single reference standard, distortionless or otherwise.

Finally, substandards would be used under defined conditions in appropriate representative circuits for the purpose of testing the "service" or "commercial" efficiency of instruments of their own type. Thus the reference standard would remain in the background as a common scale zero for all telephone concerns and a useful instrument for research and development while the actual procedure and circuit conditions to be adopted in comparing the instruments used by any telephone undertaking would be entirely unfettered.

The Transmission Unit

By R. V. L. HARTLEY

Engineering Department, Western Electric Company, Inc.

IN what units telephone engineers express the grade of transmission of a telephone connection is a question of both technical and commercial importance. The advances that have been made in long distance telephony, both by wire and by radio, are emphasizing the need of cooperation in Europe in the engineering and operation of interconnecting systems. The simplifications in engineering specifications that would result if the present diversity of units in Europe could be replaced by a single one are obvious. At the same time the interchange of information through the technical press would be greatly facilitated.

The experience of the engineers of the Bell System led them, a short time ago, to the conclusion that the type of unit discussed in this paper is the most suitable for present conditions in the telephone art. This unit is called, for the present at least, the "transmission unit" and abbreviated *T.U.*¹ This unit was submitted for consideration to many of the leading telephone establishments of the world. The response to this proposal was favorable, in general, although there were several exceptions. The American Telephone and Telegraph Company are adopting this new unit as standard in the Bell System.²

The transmission unit is of the same general nature as the "Mile of Standard Cable at 800 Cycles" and the βl unit, both of which it is intended to replace. It is used to measure the same quantities as are now measured in those units. At the same time it is defined in such a way as to facilitate the extension of its application to meet the needs of the newer developments in the communication art. Its magnitude is very nearly the same as that of the 800 cycle mile. It is, however, so chosen as to make the use of common or Briggs' logarithms convenient in transmission computations. The number of 800 cycle miles corresponding to a

¹For convenience it is intended to dispense with periods and with *s* as indicating a number of *TU*.

²"The Transmission Unit and Telephone Transmission Reference System": W. H. Martin; Journal of the A. I. E. E., June, 1924, p. 504.

condition wherein the currents under comparison are i_1 and i_2 is given by

$$N_M = 21.13 \log_{10} \frac{i_1}{i_2} = 9.175 \log_{\epsilon} \frac{i_1}{i_2}. \quad (1)$$

If the comparison is between two powers P_1 and P_2 ,

$$N_M = 10.57 \log_{10} \frac{P_1}{P_2} = 4.587 \log_{\epsilon} \frac{P_1}{P_2}. \quad (2)$$

The number of transmission units is given by

$$N_{TU} = 10 \log_{10} \frac{P_1}{P_2} = 4.343 \log_{\epsilon} \frac{P_1}{P_2}. \quad (3)$$

This may also be written

$$N = \frac{\log \frac{P_1}{P_2}}{\log 10^{0.1}},$$

from which it follows that the *TU* is a logarithmic measure of power ratio and is numerically equal to $\log 10^{0.1}$.

The use of powers rather than currents is connected with the breadth of application already referred to, and will be discussed in more detail later. In case the currents associated with the powers under comparison are proportional to the square roots of the powers, then

$$N_{TU} = 20 \log_{10} \frac{i_1}{i_2} = 8.686 \log_{\epsilon} \frac{i_1}{i_2}. \quad (4)$$

Similarly the number of βl units is given by

$$N_{\beta l} = \log_{\epsilon} \frac{i_1}{i_2} = 2.303 \log_{10} \frac{i_1}{i_2} \quad (5)$$

$$= 0.5 \log_{\epsilon} \frac{P_1}{P_2} = 1.1513 \log_{10} \frac{P_1}{P_2}. \quad (6)$$

CHOICE OF THE TRANSMISSION UNIT

Nature of the Unit

The reasons for selecting this particular unit rather than some other will probably not be obvious at first sight. They should, however, become apparent as we run over what the requirements for such a unit are, and in what

respects the various possible units may differ from one another.

The "mile of standard cable" as originally used gave a means of comparing the loudness of the sound emitted by a receiver under any two conditions in terms of the number of miles of actual physical cable that had to be inserted under one of the conditions to make the two of equal loudness. In practice, of course, adjustable artificial cables were used. The definition of the unit then was in terms of the constants per mile of the cable chosen as standard. Unfortunately two slightly different cables have become standard. That used in America has a loop resistance of 88 ohms and a capacity of .054 microfarads per mile. Some of the other countries use a cable of the same resistance and capacity which has in addition an inductance of 1 milhenry and a conductance of 1 micromho per mile.

The effect on the output of the receiver of inserting such a cable is much greater at high frequencies than at low; that is, it distorts the speech at the same time that it attenuates it. Moreover, the distortion increases with the length of the cable used. This distortion was rather a desirable property so long as the use of the unit was confined to talking comparisons of lines having roughly the same distortion as the standard cable. This condition no longer exists, however. Many of the circuits now in use have much less distortion than has a length of standard cable having the same attenuation. Also the unit is used to express the effect of inserting pieces of apparatus whose frequency characteristic bears no resemblance to that of the cable. In America at least the use of voice testing in the plant has been practically replaced by methods employing sine wave currents and electric measuring instruments. As these tests may be made with currents of various frequencies, it is important that the results be expressed in units which are independent of the frequency.

As this need arose it was natural to adapt the existing unit to meet it. Thus the effect of the circuit under test for a current of any particular frequency came to be compared with that of the standard cable for a current of one standard frequency; namely, 796 cycles per second, for which $2\pi f = 5000$. In this way a new unit was

introduced which came to be called the "800 Cycle Mile." It has, of course, two slightly different values corresponding to the two specifications for the standard cable. So far as our further discussion goes we may eliminate the original mile of standard cable as a possible unit on the ground that it fails to meet the fundamental requirement of being independent of frequency.

Before proceeding, however, let us look more carefully at what was involved in the transition to the 800 cycle mile. The artificial cable box has been replaced in substitution measurements by an artificial line calibrated in 800 cycle miles, which is made up of resistances only and so has the same effect on all frequencies. This fact tends to suggest that the 800 cycle mile, like the mile of standard cable, has, or may have, an actual physical existence. This, however, is not the case. The 800 cycle mile is a purely theoretical unit based on certain mathematical relationships. This is evident from the fact that the specifications to be met in designing a "resistance line" are that the overall effect shall vary with the length in the prescribed fashion, whereas the magnitude of the resistances used and their particular arrangement in the circuit is immaterial. The theoretical nature of the unit is still more evident when it is used for expressing the transmission of a system as determined by the ratio of two electric quantities such as currents, which may have been either measured or computed without making use of any artificial line.

The relation which defines the unit is that which connects the number of miles of standard cable with the effect which it produces at 800 cycles. The particular effect which came to be most commonly taken as a criterion was the ratio of the received current before and after the insertion of a length of standard cable. To avoid ambiguity due to terminal conditions, the line was assumed long enough so that the effect of the inserted cable is independent of the impedances at the ends of the cable in which it is inserted. The ratio of the currents under these conditions is identical with that of the currents at two points in an infinite line separated by a length equal to the number of miles inserted. This ratio $\frac{i_1}{i_2}$ is an exponential func-

tion of the distance x , which, because of the occurrence of the naperian base ϵ in line theory, is ordinarily expressed in the form

$$\frac{i_1}{i_2} = \epsilon^{ax}, \quad (7)$$

where a is a constant depending on the cable and the frequency. It should be noted, however, that the use of ϵ is purely arbitrary, as the relation can be completely expressed with a single constant as,

$$\frac{i_1}{i_2} = b^x, \quad (8)$$

where

$$b = \epsilon^a. \quad (9)$$

For the standard cable in use in America a is 0.109, from which

$$b = 1.115 \quad (10)$$

The arbitrary introduction of this unnecessary constant ϵ is only justifiable if it simplifies the treatment of the whole problem. Since, as will be brought out more fully later, it is uniquely related to only a small part of transmission engineering, its inclusion at this point tends rather to confuse than clarify the situation.

Expressing the number of units x as an explicit function of the current ratio gives

$$x = \frac{\log \frac{i_1}{i_2}}{\log b}. \quad (11)$$

From this expression we may deduce the nature and magnitude of the 800 cycle mile as a unit. If we wish to find the number of seconds in any interval of time we divide the length of the interval by the length of the second. If we want the number of hours we divide by the length of the hour. Here the quantity which the unit expresses is the logarithm of a current ratio. The number of units x is the logarithm of the ratio being measured divided by the unit, which is $\log b$. Thus the nature of the unit is the logarithm of a current ratio. Its magnitude is the logarithm of that particular current ratio b which is chosen for defining it; in this case 1.115. It should be noted that (11) is true regardless of the base of the system of logarithms used. *The numerical value of the unit will, of course, vary with the base chosen, but the*

number of units corresponding to the particular current ratio will not.

The βl unit is of the same nature as the 800 cycle mile, and differs from it only in its magnitude, which has been selected to facilitate the computation of the transmission of a long line from its primary constants. Its theoretical basis is more obvious than in the case of the mile, although its evolution from the theory of line transmission has tended to associate it more closely with long lines than is perhaps justified in view of the other uses to which it is now put. Thus while the idea of its being the product of a length by an attenuation per unit length is retained in the symbol βl , for practical purposes a single letter would be equally useful.

The βl unit, like the 800 cycle mile, is the logarithm of a current ratio. The number of units is given directly by the natural logarithm of the current ratio in question. Thus in (7) a is unity. This means that in (11) b is equal to ϵ , and so the unit itself is $\log \epsilon$. When expressed in natural logarithms the absolute value of the unit is therefore unity, as would be expected.

The TU is like the other two units in that it is defined theoretically and measures the logarithm of a ratio. The fact that the ratio measured is that of powers rather than currents is a separate question from that of its meeting the fundamental requirement of being the logarithm of a ratio.³ The magnitude of the transmission unit is readily deducible from the relation given in (3). Dropping subscripts, this may be written

$$\frac{P_1}{P_2} = 10^{0.1N} = b^N, \quad (12)$$

where

$$b = 10^{0.1}. \quad (13)$$

Corresponding to (11) then,

$$N = \frac{\log \frac{P_1}{P_2}}{\log 10^{0.1}}. \quad (14)$$

Following the same reasoning as was applied to (11) with reference to the 800 cycle mile, we

³ Units of this general type are not confined to transmission, but have come into use for expressing various ratios. Thus the octave and the musical tone are units of different magnitudes for expressing the logarithm of a frequency ratio. The stellar magnitude is one for expressing the logarithm of the ratios of the light received from the stars. They all are aimed at substituting addition for multiplication in combining ratios.

see that the TU is a unit for expressing the logarithm of the ratio of two amounts of power, and that it is numerically equal to the logarithm of a power ratio of $10^{0.1}$. When common logarithms are used its value is 0.1 and the number of units corresponding to any power ratio is ten times the common logarithm of the ratio.

Reasons for Using Power Ratio

Before discussing the reasons for proposing a unit based on power rather than current ratio some misunderstanding may be prevented by pointing out that the power ratio as here used is not to be confused with the ratio commonly used for expressing the efficiency of electrical or other machinery. It is not necessarily the ratio of the power delivered by a device to that entering it, but may be the ratio of any two amounts of power whatsoever. Just what powers are to be taken in any case will be determined by what quantity is being measured in transmission units and how that quantity is defined. It may, for example, be the efficiency of a system as compared with some reference system, the crosstalk between two lines, or the relative power at two points in a system.

No attempt will be made here to define these quantities beyond pointing out that it can be done more generally in terms of powers than currents. As the general includes the special, such a definition need not interfere with the practical use of currents under those conditions where this gives satisfactory results. That there are, however, conditions under which this is not the case is evidenced by the fact that in certain branches of transmission engineering the "800 cycle mile" has already come to be used as a unit defined on a power basis. In laying out a circuit containing a number of repeaters it is customary to construct what is called a transmission level chart.⁴ Corresponding to each point along the circuit is plotted the "level" at that point relative to some point, usually the entrance to the long distance line, which is taken as a reference level. The level at any point is determined by the ratio of the power passing that point to that passing

the point of reference. The purpose of such a chart is to indicate on the one hand what power the various repeater tubes will be called upon to handle, since they are limited in this respect, and, on the other hand, what is the ratio of the power of the voice currents to that of the interfering currents. This ratio is important because it determines the detrimental effect of the interference when it reaches the listener. These relative levels are most conveniently plotted in logarithmic units, so it was natural to use 800 cycle miles. Since, however, the impedances of the various line sections and of the apparatus including vacuum tubes vary over a wide range, a very misleading picture would be obtained if the ratios of the currents at the various points to that at the reference point were used directly in calculating the levels. To avoid this difficulty and still permit the use of formulæ based on the mile as defined in terms of current ratio, the square root of the power at the various points has come to be used as a sort of fictitious equivalent current. Had the impedance been the same at all points, the use of the currents directly would have given a correct picture.

This example serves to illustrate the arguments in favor of the power ratio unit. It brings out the fact that the really important quantity in transmission is the power. So long as the powers under comparison are associated with equal impedances, the corresponding currents give a correct measure of relative powers. In the earlier stages of the art very few of the comparisons were between powers in unequal impedances, and so a current unit was satisfactory. The more recent developments, particularly those associated with the use of vacuum tubes, have introduced an increasing proportion of cases in which the impedances are unequal, and hence an increasing demand for a unit which expresses power ratio regardless of the associated impedances. Such an extension of the unit in no way interferes with the use of current ratios in cases involving equal impedances, such as the computation of specific equivalents of lines, or the determination of transmission loss by observing the change in current in a fixed receiving instrument. All that is necessary here is to use twice as large a constant in the formula when computing units from the current ratio as is used for power ratios. Thus the number of TU

⁴Telephone Transmission over Long Cable Circuits: A. B. Clark; Trans. A. I. E. E. Vol. XXXVIII, Part 2, p. 1287, *Electrical Communication*, Vol. 1, No. 3, Feb., 1923.

is twenty times the common logarithm of the current ratio.

Some other illustrations of cases where a current ratio unit is inadequate may be mentioned.

Receivers are often compared by determining the ratio of the currents which must be passed through them to secure the same loudness of sound from both. Such a comparison means very little unless the impedances of the two happen to be the same. A high impedance receiver appears at a distinct advantage in such a test, owing to the fact that it receives more power for the same current flowing through it. For such a test to give a true picture, correction must be made for the difference in impedance in a manner which is equivalent to reducing the comparison to a power basis.

In computing the transmission efficiency of a line involving inserted apparatus a type of quantity which has been found quite useful is the so-called loss at a junction. This includes reflexion, transition and other similar losses. These can be expressed independently of the rest of the circuit in the form of the ratio of the power actually transferred across the junction to what would be transferred if the circuit receiving the energy were replaced by one having an impedance, as measured from the junction, bearing some prescribed relation to that of the circuit supplying the energy. Such a loss is expressible directly in terms of the power ratio used, whereas the application of a current ratio unit to such a case is forced, to say the least.

Again, in the application of line transmission methods to radio telephony⁵ level diagrams similar to those on long lines are useful. Here we may wish to compare power in the form of ether waves with that in the form of currents in wires. Just what currents would here be used is not obvious.

In the treatment of the mechanically vibrating parts of a telephone system, such as a receiver, there is a tendency in the direction of considering the electrical and mechanical parts as a continuous transmission system. In such an arrangement the comparison of electric and mechanical power at two points would be

natural in terms of a power ratio unit, whereas the analog of a current ratio would be the ratio of current to mechanical velocity.

It might be argued that the use of a power ratio would be undesirable because there is no instrument available which measures power directly. This difficulty is, however, more apparent than real. Power is commonly measured in telephony by measuring a current (or voltage) in an impedance which is known either by measurement or by computation. The use of current ratios as a measure of transmission is all based on an implied knowledge of the impedances involved, or at least of their relative values. Where this knowledge is available no more measurements are required to give the necessary information about the powers than about the currents. Where it is not available the same steps as are involved in measuring powers must be taken before a knowledge of the currents can have any significance as a measure of transmission. The desire to measure power arises from its own importance in engineering, and not from any arbitrary selection of a unit. That it cannot be measured directly may perhaps be considered unfortunate, but it would be more unfortunate still if, having measured it by indirect methods, no units were available for expressing the result.

Nor does a definition in terms of power ratio do any violence to the concept of the unit as being derived from the standard cable or the so-called "unit line," which is sometimes associated with the βl unit. It will be remembered that in tracing the evolution of the 800 cycle mile there was found a point at which it was necessary in fixing the unit to choose some criterion of the effect of the cable on the wave transmitted over it. While its effect on the current has been most commonly chosen, there can be no logical reason other than usefulness for choosing this rather than any one of the other quantities which are affected, such as voltage or power. Since, however, experience is showing power to be the most useful quantity it is obvious that if the 800 cycle mile continued in use its natural evolution would be to a power basis. The same is true of the βl unit. It would seem foolish, therefore, to set up a new unit on anything but a power basis.

The question of power ratio is really one of

⁵ Application to Radio of Wire Transmission Engineering: L. Espenschied; Inst. of Radio Eng., Oct., 1922, p. 344.

making the definition of any unit of the type under consideration broad enough to meet the needs of the art. All of the proposed units may be so defined without restricting their usefulness in other directions. Assuming that this is done, the choice between them is then to be based on other considerations.

Size of Unit

Units which are independent of frequency and measure the logarithm of a power ratio may differ only in the magnitude of the unit; that is, in the ratio corresponding to one unit. Here two factors are important: the order of magnitude of the unit and its relation to the systems of logarithms in common use. Obviously the simplest units from the latter standpoint would be the logarithms of power ratios of 10 and ϵ . Their values would then be unity in the common and natural systems, respectively. However, if some other order of magnitude is more desirable it may be approximated with either system by taking a multiple or sub-multiple, just as the kilometer and centimeter are derived from the meter. The *TU* is such a sub-multiple of the simplest unit employing the base 10.

Let us consider then the approximate size of the unit regardless of the logarithmic base. This question is complicated by the fact that two quite different sizes are already in use. Those familiar with each have acquired a sense of the practical significance of any particular number of the units to which they are accustomed. Also measuring apparatus and data adapted to each unit have been accumulated. The adoption of any universal unit must therefore involve a considerable readjustment of ideas, and some expense in conversion of equipment and data. The aim then should be to make this readjustment as small as is consistent with making the most of the rare opportunity of selecting the intrinsically best size of unit.

Other things being equal, there is some advantage in a unit which bears a unique relation to the physical quantity which it measures. The *TU*, like the "800 cycle mile," represents about the least difference in loudness which can be detected by the ear without special training. From this standpoint, therefore, it is preferable to the βl unit. From the standpoint

of practical convenience the use of unnecessarily large or small numbers in expressing commonly occurring quantities is to be avoided. With a unit of the size of the *TU* it is seldom necessary to use more than two places on either side of the decimal point. Losses approaching 100 *TU* may be encountered in crosstalk considerations, for example, while the loss of an individual circuit element such as a transformer may be expressible in hundredths of a *TU*. Even such small losses may become important where the cumulative effect of a large number is involved.

The situation, then, is that the adoption of a unit of the size of the *TU* involves a considerable readjustment on the part of the users of the βl unit and a comparatively small readjustment by the much greater number of users of the 800 cycle mile. At the same time, it gives some advantages which are inherent in a unit of that general size. The adoption of a unit of the size of the βl , on the other hand, would involve practically no readjustments by those now using βl , but extensive readjustments by those using the mile. It would seem then that the greatest advantage with the least sacrifice would be given by the smaller unit.

Logarithmic Base

Coming back to the choice between a unit adapted to the use of common vs. natural logarithms, we may be guided by the general principle that in the scientific and engineering world common logarithms have been shown by their extended use to be the more convenient except in cases where some special consideration makes natural logarithms preferable. Unless, therefore, it can be shown that such a special consideration holds in the case of transmission engineering, it would be going against well established experience to select anything but common logarithms.

The occurrence of the base ϵ in formulæ for line attenuation might be advanced as such a special consideration. While it is true that the computation of the attenuation of a uniform line from its primary constants is simplified by using natural logarithms, the cases where such an advantage exists form a small and progressively decreasing part of all the uses of such a unit.

The practice in certain countries of solving apparatus problems by reducing them to equivalent smooth lines tends to give the impression that the natural base is uniquely related to a larger field of computation than is actually the case. Most of these problems can be solved at least as easily by other methods which do not introduce the natural base. There are, in fact, two distinct methods of attacking circuit problems in current use. The one which is used largely in those countries where the βl unit is employed reduces everything to its equivalent smooth line. The other, which is more generally used elsewhere, reduces the part of the circuit under consideration to a relatively simple network, which may then be solved by the application of Kirchhoff's Law. Natural logarithms are doubtless more convenient for the first method, and common logarithms for the second. So far as the theoretical man is concerned the choice of unit then would be based on which of these methods is preferable. A consideration of this question seems to indicate that of the problems encountered in practical work none are solved more easily by the first method than the second, whereas a considerable number are solved more easily by the second. If this is true, the second method should ultimately replace the first, and the demand for the base e , except for long line computations would then largely disappear.

The increasing use of interconnected lines of different types and of terminal equipment, such as repeaters and carrier current apparatus, is reducing the relative importance of long line computations. Also as a reference to the illustrations cited under the discussion of power ratio will show, there is coming to be an increasing need for expressing power ratios which are measured or else calculated by formulæ which do not involve e . Much of this work is done by men engaged in the more practical phases of engineering, to whom the convenience of common logarithms is very considerable. The fact that the ordinary slide rule gives the result directly in such cases is a point of considerable importance. On the other hand, the cases in which natural logarithms are of advantage are handled largely by men of considerable training, to whom the conversion to common logarithms

may offer a slight inconvenience in manipulation, but no theoretical difficulty.

In view of these considerations it does not appear that transmission engineering is so different from other branches as to justify a special type of logarithm.

USE OF THE TRANSMISSION UNIT

Transmission Reference System

It was emphasized in the foregoing discussion that the TU is suitable for expressing a wide variety of different quantities. Space will not permit a discussion of all these, but there is one which deserves attention because of its own importance and because of the fact that its measurement involves the use of physical standards. This is the measurement of the overall reproduction efficiency of a system for speech as compared with some reference system, the comparison being made by adjusting the "line" in the reference system so that speech is reproduced by it with the same loudness as by the system under test. The number of units in the line is then taken as the "equivalent" of the system relative to the reference system.

Two such reference systems based on the two types of standard cable are in common use, and the specifications for their construction are quite well standardized. No such general agreement exists, however, on a reference system calibrated in βl units.

It should be noted that the use of these reference systems based on miles gives the results in miles of standard cable, and not in "800 cycle miles." They are, therefore, subject to the same objections as were raised to the mile of standard cable as a unit. The transmission of the system under test is expressed in terms which depend upon the particular distortion introduced by the standard cable. Furthermore, owing to the difference in impedance between the cable and the terminal instruments reflection effects enter in such a way that when only a small amount of cable is in the circuit the loudness actually increases with increase of "line" up to a certain point beyond which it decreases. As a result certain values of reproduction can be obtained with two distinct line settings.

That the reference systems now standard are not suitable for expressing transmission equiva-

lents in TU is obvious. The Bell System has therefore, undertaken the development of a transmission reference system designed primarily for use with the new unit. While this is not fully developed and calibrated, a general idea may be given of the factors entering into its design and the form which it is taking.

In line with the fact that the TU is independent of frequency, a distortionless reference system was chosen as the ideal. It might be argued that such a system would be unsuitable for comparison with practical systems because of their distortion. However, the systems in actual use vary in distortion over a wide range, from heavy loaded cable circuits on the one hand to the very high quality systems used for transmitting and reproducing music and other entertainment material on the other.⁶ It would, therefore, be impossible to select a reference system having a distortion typical of operating conditions in general. Hence it seems preferable to refer all systems finally to a distortionless standard, thereby eliminating one variable factor.

The system which is being constructed to approximate this ideal has as its adjustable portion an artificial line of 600 ohms characteristic impedance made up of resistances and calibrated in TU . At one end is a transmitting circuit and at the other a receiving circuit. These are made as nearly distortionless as possible. Their impedances are 600 ohms pure resistance, so that no reflection effects enter at the junctions with the line. The transmitter is of the condenser type, and is connected with a multi-stage amplifier. The receiving circuit contains an amplifier and a specially damped receiver.

These circuits are to be defined by assigning to them certain conversion ratios between the acoustic and electric portions of the system. In order to minimize the readjustment of working concepts based on the present reference system it is proposed to make the receiving circuit in the new system of approximately the same efficiency as that in the old. The transmitting efficiency is then to be so chosen that some particular reproduction efficiency which is repre-

sentative of operating conditions will correspond to the same equivalent in TU with reference to the new system as it does in miles with reference to the old. Efficiencies in the neighborhood of this will then differ very little on the two systems.

The practical determination of the transmitting efficiency necessary to satisfy this condition will require a very extended series of observations, since the error in a single observation is likely to be large where the distortion is so different in the two systems. Owing to this difficulty of comparison it is probable that the distortionless reference system will be used in practice only for circuits of relatively high quality. Such routine talking comparisons as are made on ordinary commercial circuits will probably be made against sub-standards each having distortion typical of a limited class of commercial circuits. These substandards, will be calibrated against the transmission reference system by extended laboratory tests.

Numerical Relations

In the actual use of the TU , time saving devices such as tables, curves and approximate

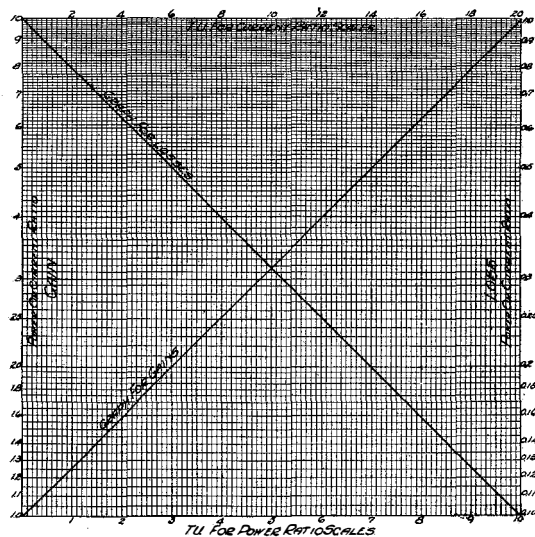

Figure 1—Transmission Unit Diagram. For power or current ratios greater than 10, move the decimal point to the left until the ratio lies between 1 and 10; and for each place the decimal point is moved, add 10 or 20 to the figures on the lower or upper scales, respectively. For power or current ratios less than 0.1, move the decimal point to the right until the ratio lies between 0.1 and 1; and for each place the decimal point is moved, add 10 or 20 to the figures on the lower or upper scales, respectively

⁶ High Quality Transmission and Reproduction of Speech and Music; W. H. Martin and H. Fletcher; Journal of the A. I. E. E., March, 1924, p. 230; Electrical Communication, Vol. II, No. 4, April, 1924.

relations are important. Of these the ordinary slide rule has probably the widest application, as it permits the conversion between a power or current ratio and *TU* to be made by a single setting. For more accurate results a table of common logarithms is sufficient. The curves of Figure 1 furnish a simple means of graphical

conversion. For very rough mental estimates the approximate relations of Table 1 are convenient. The error involved in the use of such approximations is indicated by the more exact figures given in parenthesis.

Tables 2 and 3 furnish the necessary constants for converting from the *TU* to other units.

TABLE 1

| Number of <i>TU</i> | Approximate Power Ratio | | | | |
|---------------------|-------------------------|---------|----------|------------|---------|
| | Gains | | | Losses | |
| | Fractional | Decimal | | Fractional | Decimal |
| 1 | 5/4 | 1.25 | (1.259) | 4/5 | .8 |
| 2 | 3/2 | 1.6 | (1.585) | 2/3 | .63 |
| 3 | 2 | 2. | (1.995) | 1/2 | .5 |
| 4 | 5/2 | 2.5 | (2.512) | 2/5 | .4 |
| 5 | 3 | 3.2 | (3.162) | 1/3 | .32 |
| 6 | 4 | 4. | (3.981) | 1/4 | .25 |
| 7 | 5 | 5. | (5.012) | 1/5 | .2 |
| 8 | 6 | 6. | (6.310) | 1/6 | .16 |
| 9 | 8 | 8. | (7.943) | 1/8 | .13 |
| 10 | 10 | 10. | (10.) | 1/10 | .1 |
| 20 | 100 | 100. | (100.) | 1/100 | .01 |
| 30 | 1000 | 1000. | (1000.) | 1/1000 | .001 |

TABLE 2

| | <i>TU</i> | 800 cycle mile | <i>βl</i> unit |
|--------------------|-----------|----------------|----------------|
| 1 <i>TU</i> = | 1. | 1.056 | .1151 |
| 1 800 cycle mile = | .9467 | 1. | .1090 |
| 1 <i>βl</i> unit = | 8.686 | 9.174 | 1. |

TABLE

| Multiply | by | to Obtain |
|-----------------|--------|-----------------|
| <i>TU</i> | 1.056 | 800 cycle miles |
| <i>TU</i> | 0.1151 | <i>βl</i> units |
| 800 cycle miles | 0.9467 | <i>TU</i> |
| 800 cycle miles | 0.1090 | <i>βl</i> units |
| <i>βl</i> units | 9.175 | 800 cycle miles |
| <i>βl</i> units | 8.686 | <i>TU</i> |

The Auditory Masking of One Pure Tone by Another and Its Probable Relation to the Dynamics of the Inner Ear¹

By R. L. WEGEL and C. E. LANE

Engineering Department, Western Electric Company, Inc.

Abstract: AUDITORY MASKING OF ONE PURE TONE BY ANOTHER—Using an air damped telephone receiver supplied with current with a proper combination of two frequencies, as source, the amount of masking by tones of frequency 200 to 3,500 was determined for frequencies from 150 to 5,000 per sec. The magnitude of a tone is taken as the logarithm of the ratio of its pressure to the threshold value, and masking is taken as the logarithm of its threshold value with masking to that without. The curves of masking as function of magnitude are approximated straight lines as a rule except for rounded feet, of slope s intersecting the magnitude axis at minimum masking magnitude m . For a given masking frequency n the slope increases from zero through nearly 1.0 for a frequency near n , then more slowly, approaching about 3 to 4 for the highest frequencies measured. The intercept is small or zero below n , then increases rapidly, approaching the value 3 for high frequencies. Except when the frequencies are so close together as to produce beats, the masking is greatest for tones nearly alike. When the masking tone is loud it masks tones of higher frequency better than those of frequency lower than itself. When the masking tone is weak, there is little difference. If the masking tone is introduced into the opposite ear, no appreciable masking occurs until the intensity is sufficient to reach the listening ear through the bones of the head. At intensities considerably above minimum audibility, there is no longer a linear relation between the sound pressure and the response of the ear. Data are given showing *combinational tones* resulting from this non-linearity when two tones are simultaneously introduced in the ear. The presence also of *subjective overtones* in a loud tone accounts for the large amount of masking of tones higher than itself by a loud masking tone.

DYNAMICS OF INNER EAR—The data on masking together with Knudson's data on frequency sensibility are interpreted in terms of the *dynamical theory of the cochlea* which ascribes its frequency selectivity to a passing of vibrations along the basilar membrane and a shunting through narrow regions of the membrane at points depending on the frequency. Conjectured curves are given for a few single frequencies of the amplitude of vibration of this membrane as a function of the distance along it.

PART I—AUDITORY MASKING OF ONE PURE TONE BY ANOTHER

1. INTRODUCTION

IN past work on audition very little attention has been given to the phenomenon of masking. A. M. Mayer² has left a more complete record of observations on masking than any one else. He concludes that low frequency sounds may completely "obliterate" higher frequencies of considerable intensity but higher frequencies do not "obliterate" lower ones. In his experiments he used organ pipes for low

frequencies and tuning forks for the high ones. With the organ pipe sounding, the action of the fork could be made intermittent by moving the hand to and fro over the mouth of a resonance box with which it was used. He describes his results in part as follows: "As the vibrations of the fork run down in amplitude, the sensations of its effect become less and less until they soon entirely vanish. Indeed the vibrations of the forks may be suddenly and totally stopped without the ear being able to detect the fact. But if instead of stopping the fork when it becomes audible, we stop the sound of the organ-pipe, it is impossible not to feel surprised at the strong sound of the fork which the open pipe had smothered and had rendered powerless to affect the ear. No sound, even when very intense, can diminish or obliterate the sensation of a concurrent sound which is lower in pitch. This was proved by experiments similar to the last, but differing in having the more intense sound higher (instead of lower) in pitch."

The experiments of Mayer are, of course, only qualitative. The work described in this paper was undertaken to obtain quantitative data and to find an explanation for the phenomena observed.

2. Definition of Masking. Unless otherwise specified, whenever the term masking is used, it is intended to mean the masking of one tone by another when both are introduced in the same ear. For convenience in presenting data, the magnitude of a tone is defined as the ratio of its pressure to that of its minimum audible value. A logarithmic scale is used in plotting. If a minimum audible pressure of one tone is p_1 and the introduction of a second tone changes its minimum detectable value to p_2 , the ratio p_2/p_1 is taken as the magnitude of the masking of the first tone by the second and is likewise plotted on a logarithmic scale. In this paper the term pressure is used to signify the root mean square value of the sound pressure in the external ear passage.

¹ Published in *The Physical Review*, Second Series, Vol. XXIII, No. 2, February, 1924.

² Mayer, *Phil. Mag.* 11, 500, 1876.

3. *Range of Intensities and Frequencies of the Tones Used.* Figure 1 is a diagram of the auditory sensation area.³ This figure practically describes itself. It shows that the region of sensation covered by these experiments includes the most important range of frequencies and intensities. The higher levels in this region near the threshold of feeling are generally impracticable for extended experimentation because they induce tinnitus. The very low and

cession at one time. In all figures the masking tone is designated by F_1 and the masked by F_2 . These curves were all obtained for one observer except the dash-dot ones, which are included here to show the small amount of variation usually found when taking masking data for different observers of normal hearing.

The curves do not all pass through the origin as they evidently should except, as will be explained later, when the tones produce beats.

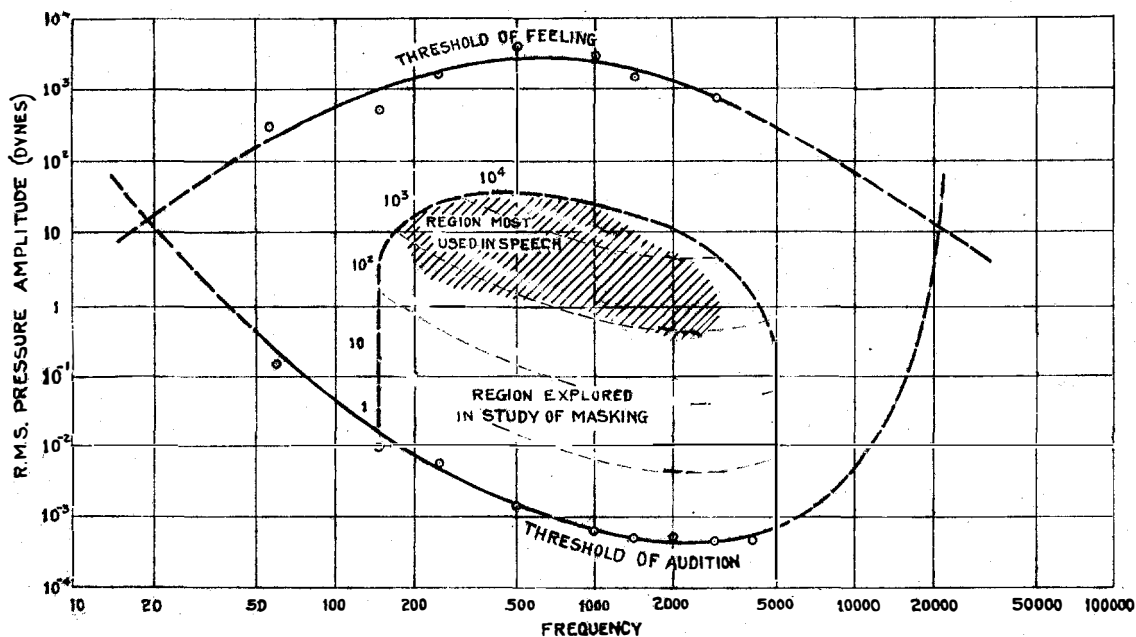

Figure 1—Auditory Sensation Area

very high frequencies are not covered in this work because they are of lesser importance, and furthermore, intense and pure tones at low frequencies and intense tones at high frequencies are produced with difficulty.

4. *Masking as a Function of Intensity.* Figure 2 shows the amount of masking of various frequencies from 250 to 4,000 cycles produced by an 800 cycle tone, plotted as a function of the magnitude of this masking tone. For example, the first curve shows the amount of masking, as already defined, of 250 cycles plotted as a function of the magnitude of an 800 cycle masking tone. Each plotted point represents the average of four observations taken in suc-

The minimum audible reference value used was the average taken over a period of several days. Plotted in this way it was found that such curves varied from day to day near minimum audibility but for the higher intensities checked within the experimental error. The general magnitude of the deviation of the lower end of the curve from the origin will be seen from the variation shown by the curves. This shows that the ear is quite variable in its behavior near minimum audibility, but comparatively constant for louder tones. The curves as corrected by the dotted lines represent a close approximation, in each case, to the average curve which would have been obtained if the observations had extended over a long period of time. This correction does not apply when the tones produce beats.

³ See Wegel, Proc. Nat. Acad. Sci., July, 1922, Bell System Tech. Jour., Nov., 1922, *Electrical Communication*, Nov. 1922, Vol. I, No. 2.

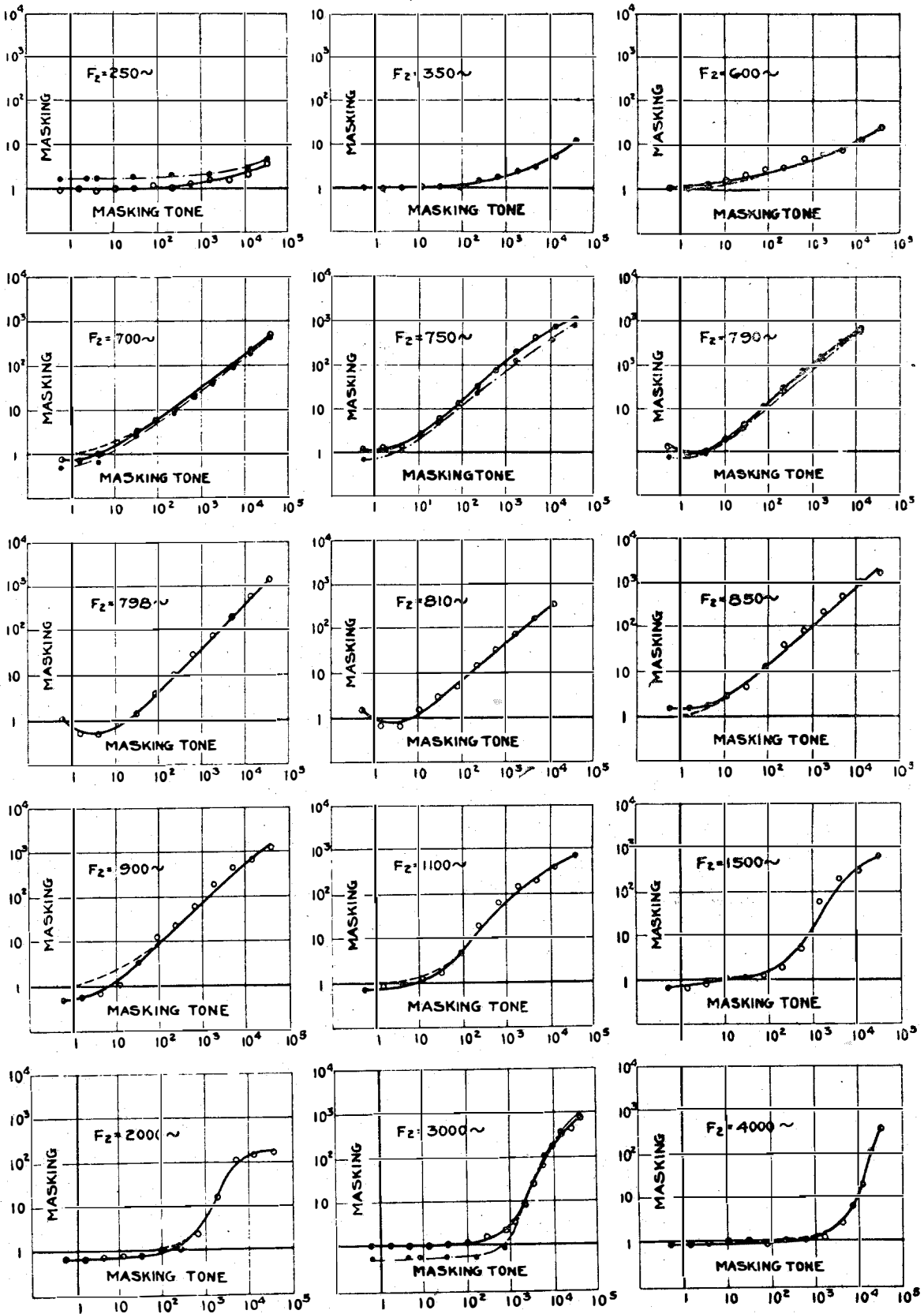

Figure 2—Data for Masking Tone of 800 Cycles

Figure 3 shows some of the corrected curves from Figure 2 reproduced on common axes. Curves for masking tones of 200, 300, 400, 600, 1,200, 1,800, 2,400 and 3,500 cycles are also included in this figure. The frequency of the masked tone is indicated on each curve.

when the tones lie close together, the curves approaching straight lines with 45° slopes, intercepting the axis of abscissas at about ten times the minimum audible pressure of the masking tone.

When the tones are close enough together in

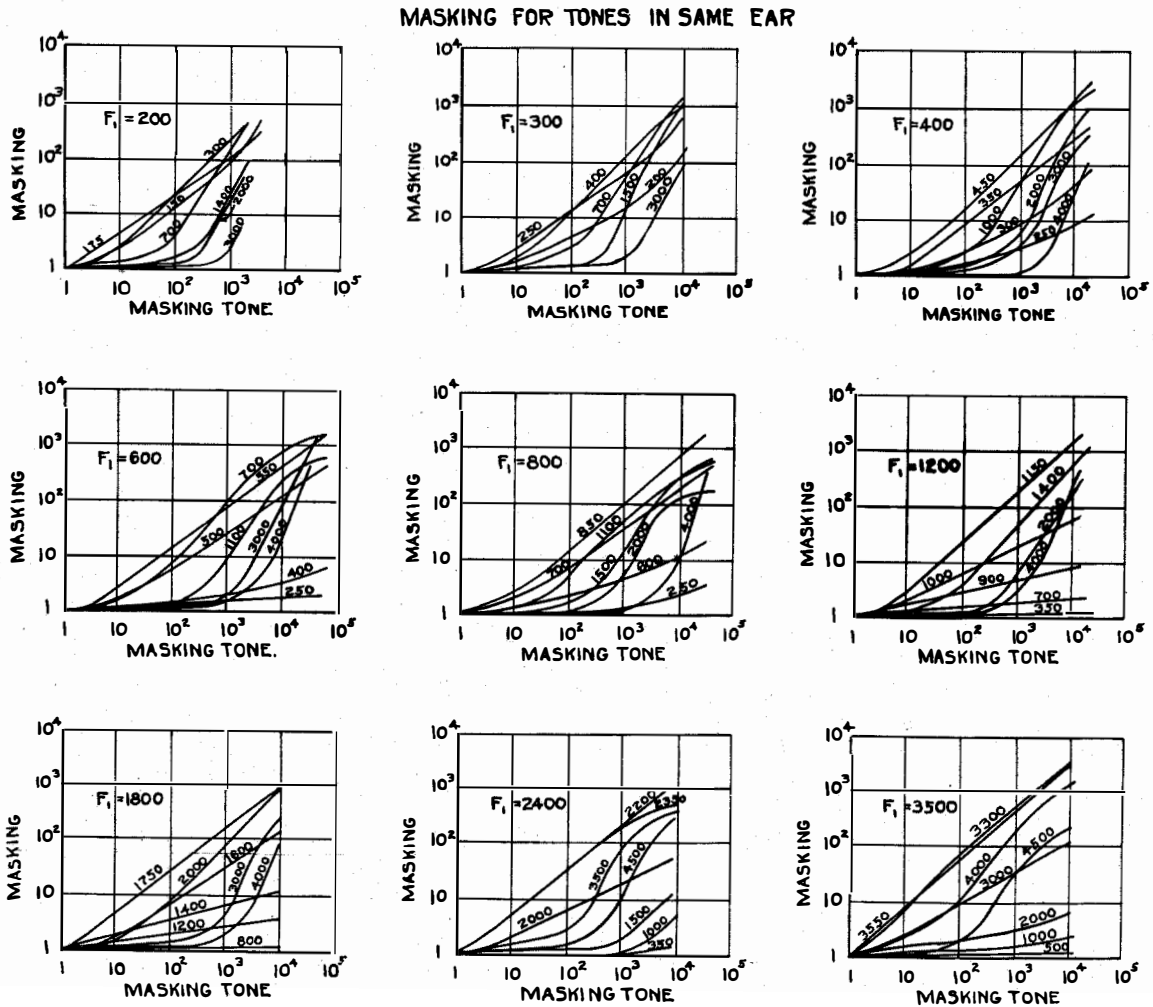

Figure 3—Masking for Tones in Same Ear

From the figures certain general facts are evident. A tone of a frequency much below the masking tone is not perceptibly masked for the lower range of intensities and hardly more than perceptibly so when the tones are very loud. A tone of much higher frequency than the masking tone is not perceptibly masked for the lower range of intensities, but at a rather definite high intensity masking occurs perceptibly and quickly becomes very great as the masking tone is increased. In general, masking is greater

frequency to beat, they do not give masking curves in the same sense as when farther apart. They represent measurements of the minimum perceptible fluctuation of the beating tone. Two such tones, separately inaudible, but each not lower than one-half the minimum audible pressure, will obviously beat when introduced together in such a way as to be alternately audible and inaudible. This effect accounts for the depression in the curve at low intensities in Fig. 2 for F₂ = 790, 789 and 810. At higher

intensities the magnitude of the minimum perceptible beating fluctuation may be obtained from the difference between abscissas and ordinates. The minimum detectable amount of this fluctuation has been found to decrease as the beat frequency decreases, approaching a value which should be expected from ear sensibility data.

The sudden increase in slope of the curves

value. With the exception of the region near the masking frequency where beats occur, the lowest curve shows a gradual falling off of masking as the masked frequency departs on either side from the masking frequency. Within the region of beats, the amount of masking decreases as the masking frequency is approached. The intersection of the curves at the masking frequency may be interpreted to

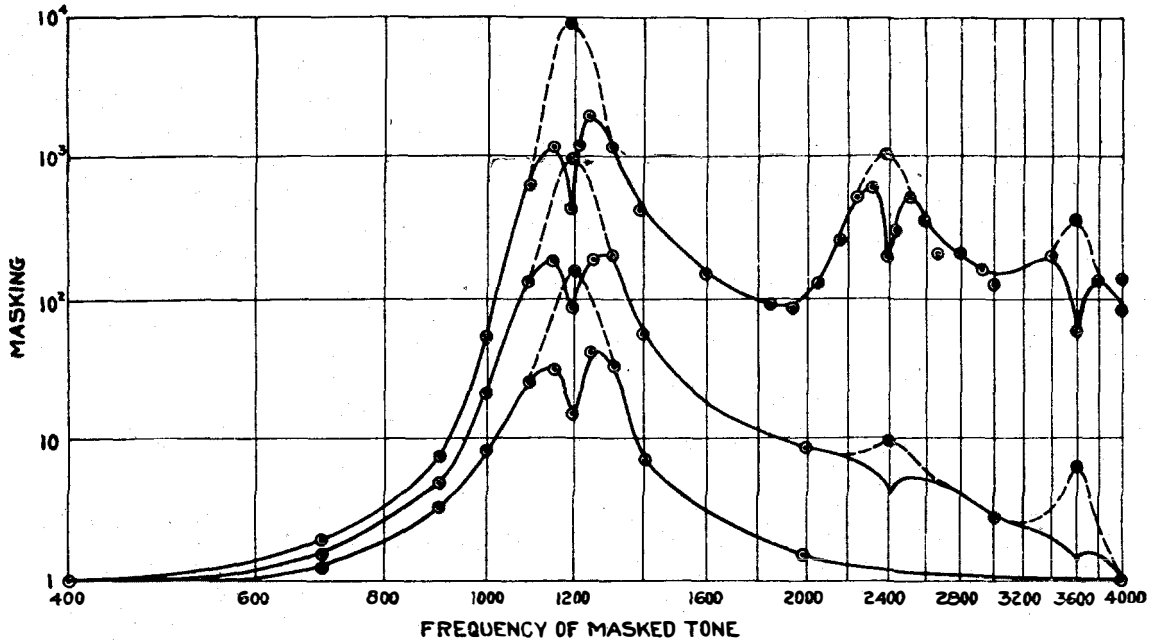

Figure 4—Masking of Various Frequencies by 1,200 Cycles

when the masked frequency is higher than the masking frequency is associated with the appearance of combinational tones. The curve in Figure 2 for $F_2=2,000$ shows a decided bending over at high intensities. This and similar bendings may be accounted for on the supposition that both tones are conducted through the head to the opposite ear in such relative amounts that the masked tone is detected there while it is still masked in the ear to which the sound is applied. It has been found that a small amount of bone conduction takes place between the receiver ear cap and the mastoid bone. The phenomena of combinational tones and head conduction will be discussed later.

5. *Masking as a Function of Frequency.* Figure 4 shows the masking of tones of various frequencies by a masking tone of 1,200 cycles at 160, 1,000 and 10,000 times its minimum audible

give intensity sensibility. The highest curve differs in that its characteristics in the region of the first and second overtones of the masking frequency are much like those in the neighborhood of the masking frequency. It resembles such a curve as might be expected from a knowledge of the lowest curve if three masking frequencies, 1,200, 2,400 and 3,600 cycles were present, with relative magnitudes of 1:0.1:0.025. An harmonic analysis of the sound as picked up by a condenser transmitter, showed that these tones were not appreciably present in the air. These and other tests were made, in fact, in all measurements recorded in this paper, and in no case was the distortion in the receiver detectable. Since beats are obtained at the frequencies of overtones, it is concluded that these harmonics are introduced subjectively in the ear due to some non-linear characteristic

of its response. The magnitude of these overtones may be obtained experimentally by increasing the intensity of a secondary tone of such a frequency as to beat with the harmonic, to a point where beats are most prominent and taking the intensity of this tone to be equal to the intensity of the overtone. The dots represent

ordinates. The continuous curve is the same as the top curve in Figure 11. The various areas represent ranges of magnitude and frequency of the secondary tone in which combinational tones of various kinds, as indicated, appear. As any secondary tone of a frequency below about 1,000 cycles, for example 800, is

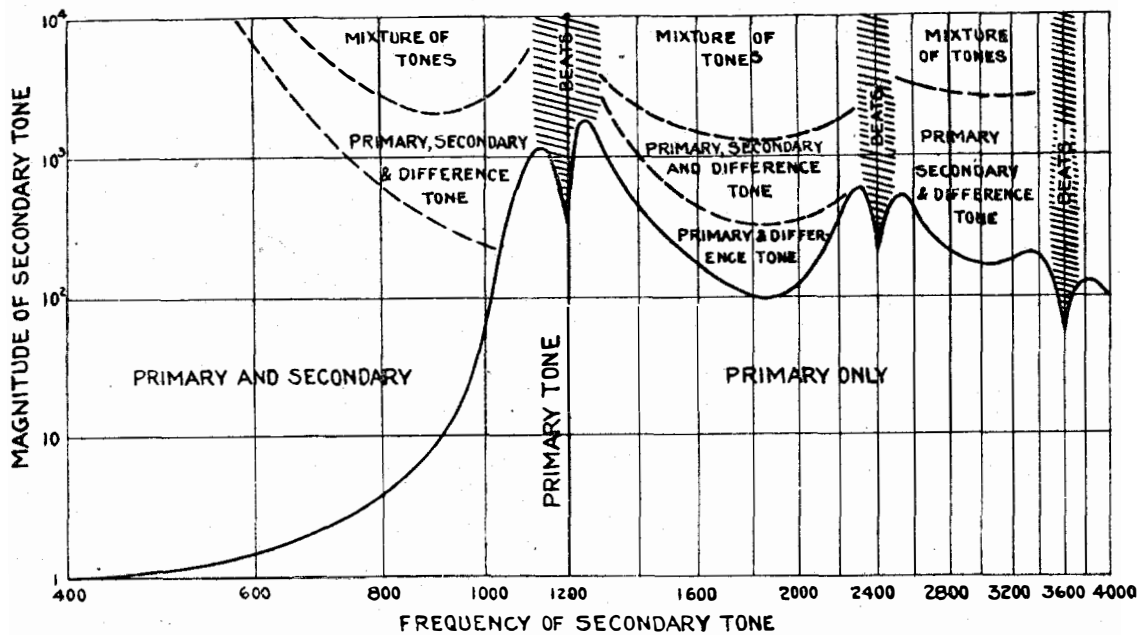

Figure 5—Sensation Caused by Two Pure Tones

the magnitude of the harmonics so determined. This method is not very accurate because the intensity of the variable tone at which the most prominent beats are heard tends to be somewhat higher than the fixed overtone. The middle curve represents a transition between the other two. It indicates harmonic components of relative magnitudes 1: .01: .006. These curves show that a tone masks frequencies higher than itself better than lower frequencies only when it is loud.

6. *Non-Linearity of Response of the Ear.* The character of the sensation, when two tones are acting together on the ear, varies considerably with the relative frequency and intensity values. Figure 5 represents the sensation caused by a tone of fixed frequency, 1,200 cycles, and magnitude 10^4 , in combination with various secondary tones of which the frequencies are represented by the abscissas and the magnitudes by the

gradually brought up in intensity from a sub-audible value to a point at which it is just detectable, it is first heard as a separate tone along with the primary tone. In the lower part of this range, the intensity of the secondary tone may be increased to very large values and still be perceived independently of the primary. When, however, the intensity of the secondary tone is increased to a point indicated by the dotted line, the difference tone is distinguishable and increases gradually in relative intensity as the area above this line is crossed. At the high intensities in this region, a very complex mixture of tones is heard. When a secondary tone of 1,900 cycles is introduced in the same way, its presence is first detected by a difference tone, and the secondary is not heard. As the intensity is further increased, the secondary tone becomes audible along with the difference tone. As the intensity is increased to the higher

levels, the mixture of tones becomes more and more complex. With this explanation, the meaning of the rest of the figure will be obvious.

A careful analysis was made of the mixture of tones present in the ear when a primary of 1,200 at a magnitude 6×10^4 was present along with a secondary of frequency 700, of about the same intensity. The component frequencies were determined by introducing a third tone of known variable frequency and determining the frequencies at which beats occur. If f_1 represents the primary, and f_2 , the secondary, the frequencies found in the mixture were f_1 , 1,200 cycles; f_2 , 700; $f_1 + f_2$, 1,900; $f_1 - f_2$, 500; $2f_1$, 2,400; $2f_2$, 1,400; $3f_1$, 3,600; $3f_2$, 2,100; $2f_1 + f_2$, 3,100; $2f_1 - f_2$, 1,700; $2f_2 + f_1$, 2,600; $2f_2 - f_1$, 200(?); $4f_2$, 2,800; $2f_1 + 2f_2$, 3,800; $2f_1 - 2f_2$, 1,000; $3f_1 + f_2$, 4,300; $3f_1 - f_2$, 2,900; $3f_2 + f_1$, 3,300; $3f_2 - f_1$, 900. No attempt was made to determine their magnitudes although this can probably be done approximately by measuring the intensity of the exploring tone at which the beats at each frequency are most prominent. With the exception of the frequency $4f_1$, this series is all that would be expected if the response of the ear were non-linear and represented by the equation:

$$x = a_0 + a_1p + a_2p^2 + a_3p^3 + a_4p^4.$$

In this equation, x is the response of the mechanism of the middle ear; a_0 , a_1 , a_2 , etc., are constants, and p is the pressure in the ear canal. While frequencies introduced by higher powers of the pressure were probably present, they were very faint and no careful search was made for them. No careful investigation has yet been made of this phase of audition. Results of further work may call for modifications of the interpretation given here. It may be interesting to note in this connection that one of the striking characteristics of some kinds of abnormal hearing has been found³ to be an exaggerated departure from linearity.

7. *Masking with Tones in Opposite Ears.* Figure 6 gives the masking when the masked and masking tones are introduced in opposite ears. The dotted curves show the corresponding data for tones in the same ear. The two sets of curves are nearly alike except for displacement in the ratio of 1:10² to 1:10³ along the horizontal axis. These curves may be explained

by assuming that there are two kinds of masking, central and peripheral, the former being generally relatively small and resulting from the conflict of sensations in the brain and the latter originating from overlapping of stimuli in the end organ. Central masking is probably always present to a certain extent whereas peripheral masking can only occur when the two tones excite the same region on the basilar membrane. All large amounts of masking may be attributed to peripheral masking. The similarity, except for the displacement already noted, of the two sets of masking curves indicates that most of the masking for loud tones in opposite ears is peripheral masking, caused by the conduction of the masking tone through the head to the opposite ear with sufficient intensity to cause peripheral masking there. This presumes an attenuation of the tone through the head from one ear to the other of the same order of magnitude as the displacement between the two sets of masking curves.

The magnitude of the masking tone in these experiments was referred to the minimum audible value for the ear into which it was introduced. The magnitude of the masking was referred to the minimum audible value for the opposite ear. It will be seen, therefore, according to the explanation offered above, that the amount of displacement of a curve gives the sum of the conduction loss through the head and the difference in sensitivity of the two ears. If both had been referred to the minimum audible value of the ear receiving the masked tone, the displacement would have given the attenuation through the head. Since the two ears of the observer did not differ greatly in sensitivity, this displacement gives the proper order of magnitude for the attenuation.

There is still further evidence that when a tone is introduced into one ear by a telephone receiver, the opposite ear is also excited but to a lesser degree. Cases of persons very deaf in one ear have been noted for which 10² to 10³ times the current is required for audition with the receiver on the deaf ear over that for the receiver on the good ear. Also, when the sound for the receiver on the deaf ear is audible, it may be greatly enhanced by placing the finger in the good ear, indicating that the sound is not only heard first in the good ear but that it arrives

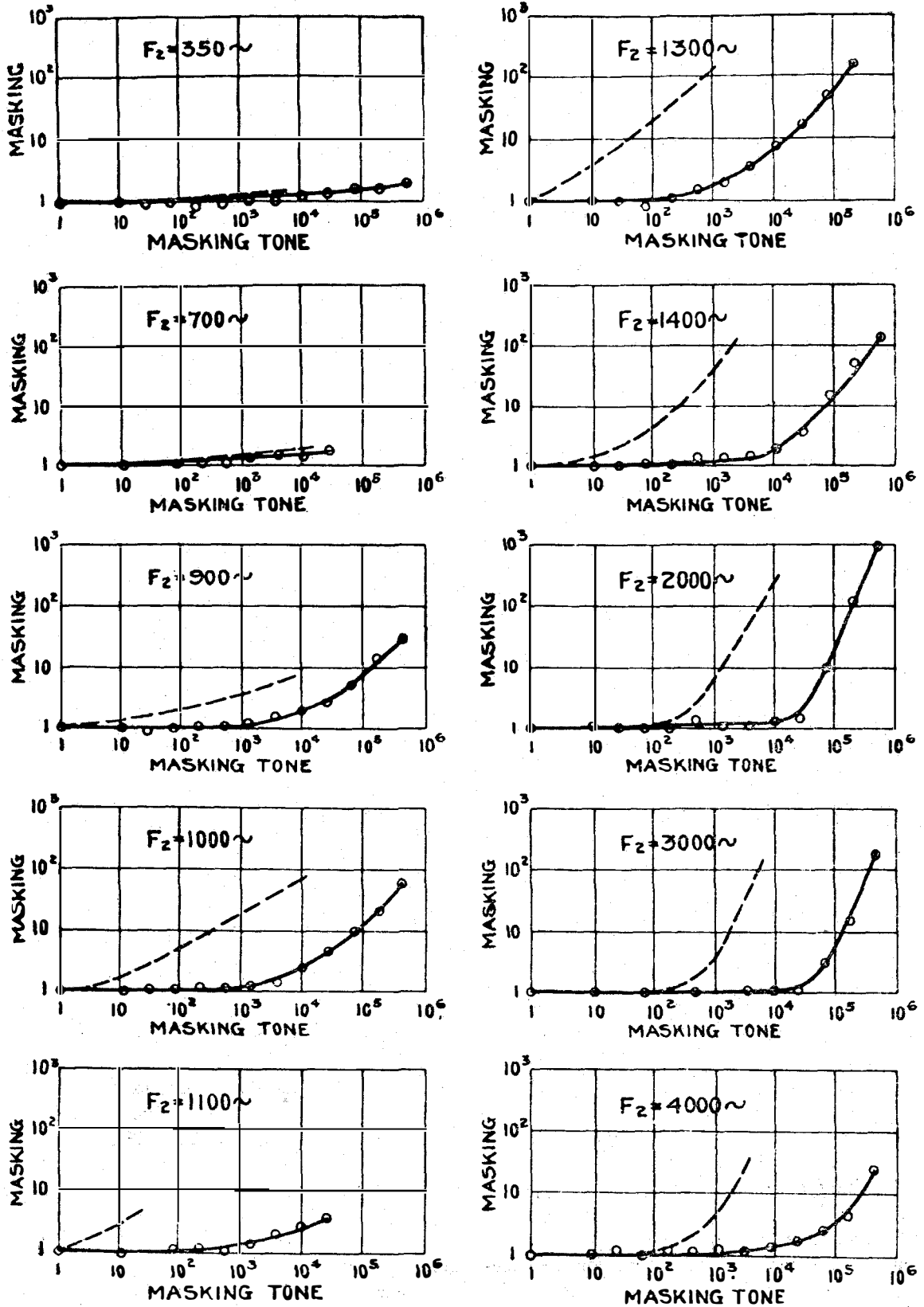

Figure 6—Masking Data for Tones in Opposite Ears, Masking Tone 1,200 Cycles

there by bone conduction. Furthermore when two tones of the proper frequencies to beat are introduced in opposite ears the best beats⁴ are always heard when one of the tones is over 100 times the amplitude of the other and the relative intensities for hearing these best beats are nearly independent of the sensitivity of the ear to which the louder tone is applied. In fact this ear may be entirely deaf, or, if normal, its sensitivity may be lowered by plugging, and best beats will still be heard at the same relative currents through the receivers.

In view of the approximate agreement of all the evidence of head conduction, it seems safe to conclude that this phenomenon actually exists and that it accounts for the resemblance of the two sets of masking curves in Figure 6. This attenuation through the head, of course, applies only when telephone receivers are used in the ordinary manner as the sound source. When other sources were used, different values of attenuation were found.

PART II—DYNAMICS OF THE INNER EAR

8. *Dynamical Theory of the Cochlea.* A consideration of the anatomy of the cochlea makes it unreasonable to suppose that the individual hair cells, basilar fibres or rods of corti can act as independent resonators, even assuming that dissipational impedance to their motion is small enough to permit of resonance. The motion of each must be greatly affected by the reactions of others due to their dynamical proximity. One element cannot resonate without setting the others in vibration and itself have a complex motion with component frequencies corresponding to all the modes of motion of the complete system which would be obtained by means of its Lagrange discriminant or the equivalent. These frequencies are not generally the resonance frequencies of the vibrating elements themselves. This sort of consideration leads to a treatment of the dynamics of the cochlea as a whole such as that explained by Roaf.⁵

The mechanism assumed here of the action of the cochlea may be explained by reference to Figure 7a, which represents the cochlea

uncoiled.⁶ The stapes, in responding to the sound pressure received through the middle ear, is displaced in the oval window, causing a mass movement of the liquid in the scala vestibuli and scala tympani, which except for a small yielding of the labyrinthine walls, results in an

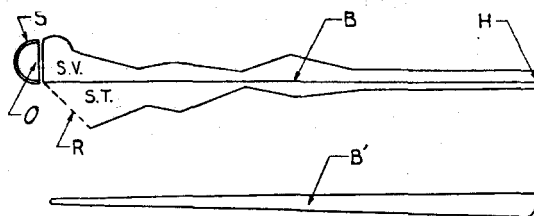

S = STAPES; O = FENESTRA OVALIS; S.V. = SCALA VESTIBULI;
S.T. = SCALA TYMPANI; H = HELICOTREMA; R = FENESTRA ROTUNDA;
B = SURFACE VIEW OF BASILAR MEMBRANE.

Figure 7a—Cochlea Uncoiled

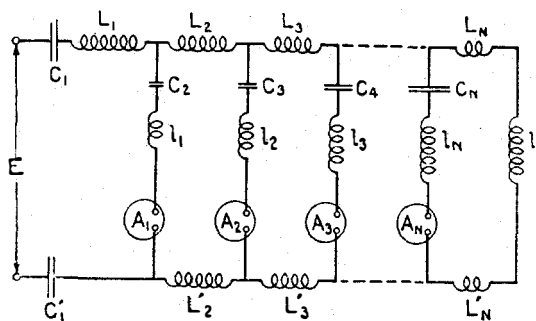

Figure 7b—Electrical Analogue of the Cochlea

equal and opposite displacement of the membrane of the round window. This mass movement of the liquid can take place only by means of the displacement of the basilar membrane or through the helicotrema. If the pressure change is very slow, the movement will take place through the helicotrema. If the pressure change is more rapid, i.e., if the frequency is increased, most of the movement will take place through the displacement of the basilar membrane. This displacement will have a well defined maximum at some definite point, the location of which depends on the frequency, and will decrease rapidly on either side of this maximum. As the frequency is increased, the position of the maximum approaches the proximal end of the membrane.

The motion of the basilar membrane in any region may be assumed to produce a stimulus of

⁶ Wrightson, *The Analytical Mechanism of the Internal Ear.*

⁴ In this connection, see G. W. Stewart, *Phys. Rev.* 9, 514, 1917. Stewart's conclusions are somewhat at variance with those arrived at here.

⁵ Roaf, *Phil. Mag.* (V) 43, 49, Feb., 1922.

the nerve terminals in that region. This stimulus may be due to the relative motion of the basilar and tectorial membranes, or flexure of the basilar membrane, or to both. In any case, the amount of the stimulus of any nerve terminal may be taken as a direct function of the motion of the membrane at the point at which it terminates.

A "lumped constant" electrical analogue of the cochlea is shown in Figure 7b. Although the analogy is not very close, its selective characteristics are similar to those of the cochlea. The inductance L_1 corresponds to the mass of the stapes and its attached parts, C_1 , the elasticity restraining its motion, C_1' , the elasticity of the round window membrane. The inductances L_2, L_3 , etc., represent elements of mass of the fluid in the scala vestibuli, L_2', L_3' , etc., similar constants for the scala tympani; C_2, C_3, C_4 , etc., the elasticities of elements of the basilar membrane; l_1, l_2 , etc., their masses as augmented by contiguous elemental volumes of fluid on either side. A_1, A_2, A_3 , etc., are ammeters corresponding to the nerve terminals on the various elements of the membrane. L_h corresponds to the element of fluid mass in the helicotrema. The series inductances decrease essentially along the structure to correspond with the decreasing cross section of the two scala. The shunt inductances vary more or less in proportion to the widths of successive elements of the membrane. The capacities increase to correspond to the increasing flexibility of the membrane due to its increasing width. Neither the exact magnitudes and variations nor the exact dispositions of the elements of this analogue can be given because the dynamical constants of the parts of the cochlea are not known. Resistances are, of course, associated in various ways with the inductances and capacities. These are not represented in the figure. This electrical network should behave much like the cochlea in that, as the frequency increases, the meter giving a maximum reading in nearer and nearer the source.

9. *Positions on the Basilar Membrane of Maximum response to Various Frequencies.* It is found that if the two points of a pair of dividers are brought in contact with the back of the hand, the minimum separation at which they can be distinguished separately is about 32 mm.

On the finger tips where the nerve terminals are more numerous this distance is about 2.3 mm. According to the theory of the cochlea given above, two frequencies nearly alike cause maximum stimulations at adjacent points on the basilar membrane. The minimum detectable difference in frequency then corresponds to the minimum detectable distance between the corresponding maxima on the membrane. The auditory nerve terminals are quite evenly distributed along the membrane so that it may be assumed as a first approximation that the space interval between two disturbances which are just separately distinguishable is the same all along the membrane. This interval corresponds to the minimum detectable frequency difference, as given by sensibility data, between the tones causing the two disturbances. If f_1 and f_2 are the lower and higher limits to which the basilar membrane responds, l_0 the total length of the membrane, l the distance from the helicotrema to the point at which the disturbance corresponding to a frequency f takes place and Δf the minimum perceptible difference in frequency:

$$l \int_{f_1}^{f_2} \frac{df}{\Delta f} = l_0 \int_{f_1}^{f_2} \frac{df}{\Delta f}$$

The distribution of frequency response along the membrane is plotted in Figure 8. This was calculated from Knudsen's frequency sensibility data and using the frequency limits 0 and 15,000

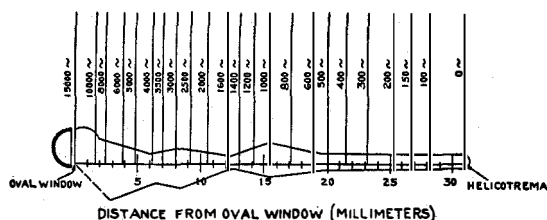

Figure 8—Characteristic Frequency Regions on Basilar Membrane

cycles and 31 mm. for the length of the membrane. The sensibility at extremely high frequencies is so small that the value of f_2 may be anything from 10,000 cycles to infinity without appreciably affecting the general distribution. Similarly f_1 may be taken as any frequency from 0 to 50 cycles without materially affecting the distribution because this range is so small com-

pared to the audible range of frequencies. The plot, Figure 8, shows that 1,000 cycles falls about at the middle of the membrane and that distance corresponding to equal frequency intervals decrease rapidly as the stapes end is approached.

It is interesting to compare the space discrimination on the basilar membrane with those on the back of the hand (32 mm.) and finger tips (2.3 mm.). The sensibility data interpreted as above give about .02 mm.

10. *Variation in Amplitude of Vibration Along the Basilar Membrane for a Single Frequency.* Figure 9 shows a hypothetical curve of the variation of the basilar membrane along its length, in response to a primary tone of single frequency. This curve has a maximum at a point in the region R_1 , and falls off rapidly on both sides. A dotted line is drawn to show the minimum amount of vibration necessary to produce perceptible stimulation of the nerve terminals along the length. It may be assumed that the nerves are nearly enough alike, along the membrane, and similarly situated, so that the actual motion necessary to produce minimum audible sensation is about the same at all points. Three other curves corresponding to three different magnitudes of the secondary tone are also

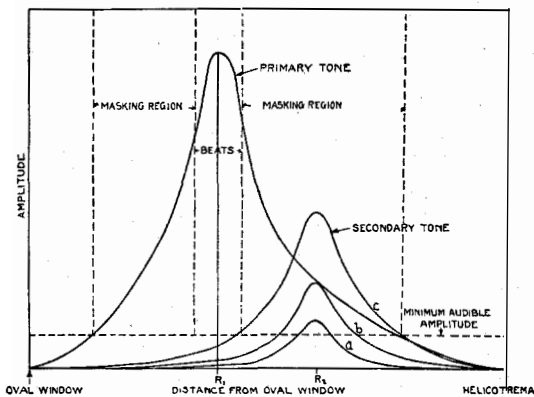

Figure 9—Hypothetical Curve of Vibration of Basilar Membrane

shown. These curves have maxima in the region R_2 . Curve *a* corresponds to a stimulus which in the presence of the primary tone is not detectable, but alone is audible. Curve *c* corresponds to a stimulus which is detectable in the presence of the primary. Some magni-

tude between curves *a* and *c* must correspond to a minimum detectable magnitude of the secondary tone. This is a magnitude at which some definite relation exists between the amplitude caused by the secondary tone in the region R_3 , and the amplitude at the same place caused by the primary tone. These amplitudes have been tentatively assumed equal in this work, that is, that the secondary tone, when just detectable, is represented by curve *b*. The acceptance of a ratio of different order of magnitude is unreasonable and a fine discrimination cannot be justified at this time. Fragmentary evidence, which will not be gone into here, indicates that the ratio should not differ greatly from unity. On this assumption, if central masking is neglected, a secondary tone may be used as an exploring stimulus to measure the amplitude of motion, due to a primary tone, of the basilar membrane at various points along it except in remote regions where the amplitude is less than that necessary for sensation, and very near the maximum, where the primary and exploring tones beat.

The maximum amplitude on the membrane due to any single tone, in units of the minimum audible amplitude of the membrane, is its "magnitude" as already defined. The maximum value of the curve of a primary tone is therefore given by its magnitude. The amplitude of vibration at any point in regions where masking occurs is given by the magnitude of masking of the exploring or secondary tone.

11. *The Curves of Vibration of the Basilar Membrane at Different Frequencies.* Figure 10 shows the vibration of the basilar membrane for different frequencies as determined from experimental data by the method described in the preceding section, for amplitudes corresponding to the same pressure of .5 dyne per cm.² in the external ear canal. This corresponds to a sound which is not so loud as to produce noticeable harmonics. The dotted curve is the locus of the maxima for all frequencies at a constant pressure of .5 dyne in the external ear canal for the ear on which the measurement was made. This curve represents the average of data taken over a long period of time so that irregularities which are usually present in a single curve are eliminated. The unit is as before the amplitude of the membrane neces-

sary for minimum audibility but the scale is arithmetic. The curves become less shape as the frequency is decreased. This is in agreement with what would be expected from the dynamical structure of the cochlea. At very low frequencies the stimulus may be conceived of as due to a more or less bodily motion of the tectorial membrane along the basilar membrane.

brane, also indicate similar sharp cut-offs at frequencies much lower than 15,000 cycles whereas no such abrupt cut-offs of lower frequencies have yet been recorded.⁸ According to this theory of the action of the cochlea, it follows that as long as there is sensitivity in any of the nerves, even if it is only in a small region, the ear will be able to detect any fre-

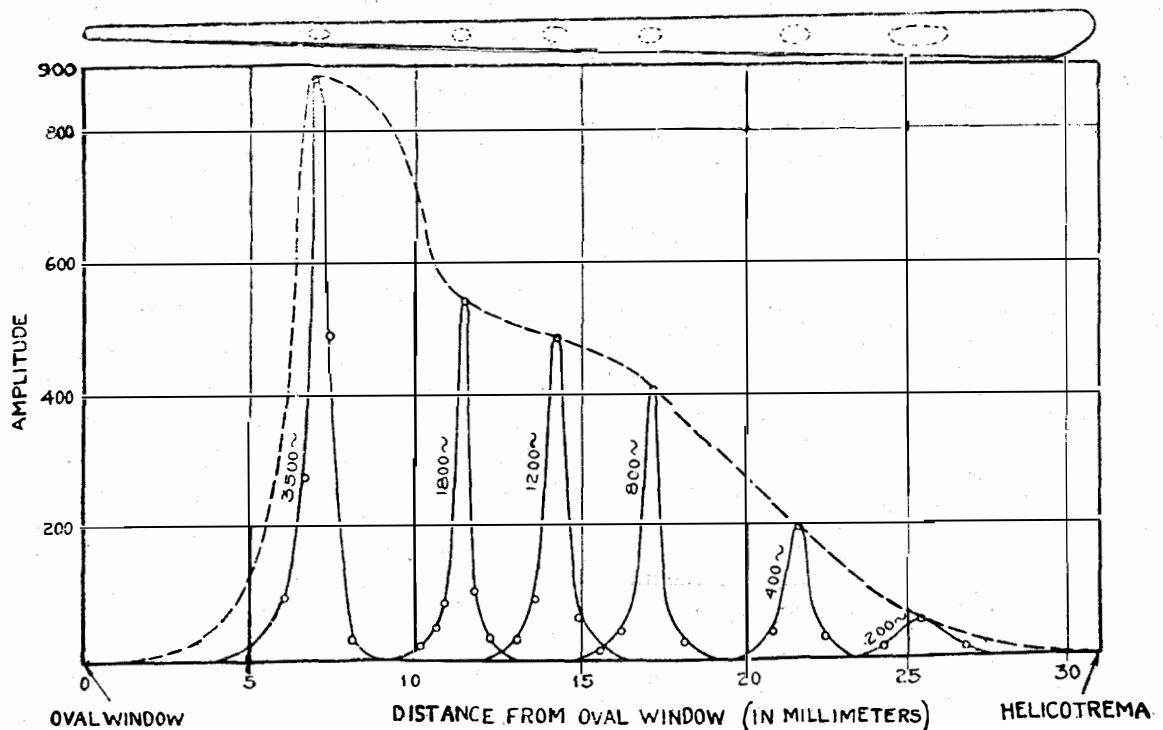

Figure 10—Amplitude Along Basilar Membrane for Different Frequencies: r.m.s. Pressure 0.5 Dynes

It is to be expected that similar curves at extremely high frequencies should become less definite, probably not by becoming flatter, but by having their maxima at or beyond the proximal end of the organ of corti. This conclusion is arrived at principally from a consideration of the curves of absolute sensitivity of normal ears (see Figure 1) in which the sensitivity is seen to drop off very sharply at about 15,000 cycles.⁷ This sort of an assumption is further substantiated by the fact that when plotted as displacement of the basilar membrane, sensitivity curves of abnormal ears in which the lesion can be reasonably well traced to degeneration of the nerves of the proximal end of the basilar mem-

quency if it is loud enough, and that it will detect with greatest sensitivity those frequencies for which the sensitive region is characteristic.

A plan view of the basilar membrane is shown drawn to scale, at the top of the figure. Conjectured contour lines are drawn enclosing areas over which the amplitude is more than one-half that of their centers. The lengths of these areas are obtained from the curves shown in the figure and their widths by taking one-half the width of the membrane.

Figure 11 shows curves of response of the basilar membrane for two frequencies, 1,200 and

⁷ For original data see C. E. Lane, *Phys. Rev.* 19, 492, May, 1922.

⁸ For example, see E. P. Fowler and R. L. Wegel, *Audiometric Methods and Their Application*, Trans. Am. Laryngological, Rhinological and Otological Society, 1922.

3,500, at constant amplitudes of the membrane of 8,000 times the minimum audible amplitude. This, of course, did not represent equal pressures in the external ear canal. The secondary maxima caused by the subjective overtones are present in each case. It seems most reasonable to ascribe the non-linearity producing these overtones to some part of the middle ear, possibly the joint between the ham-

sensed, and then passing them back to the round window where their pressures are relieved. While this interpretation is probably the simplest that could be made, and the present data seem to be in accord with it, it is, of course, possible that other satisfactory interpretations might be found, though they are not very obvious. On account of the inaccessibility of the ear, the determination of its dynamics depends on in-

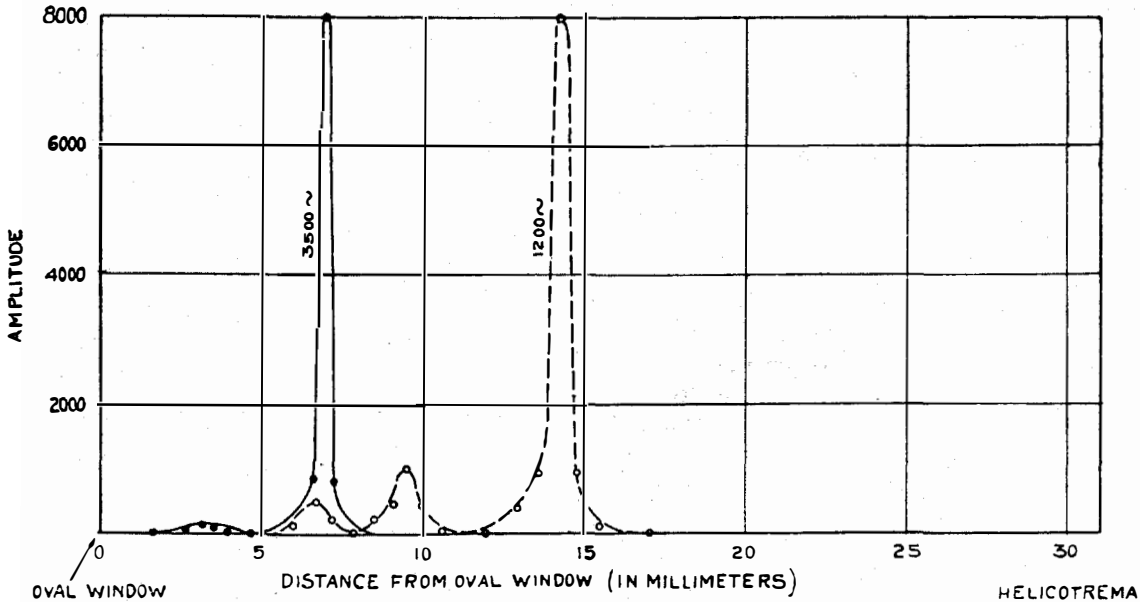

Figure 11—Amplitude Along Basilar Membrane for Loud Tones

mer and anvil which may have enough static friction to give a rubbing effect when vibrating violently.

The conjectured vibration of the membrane with two loud tones of 1,200 and 700 cycles under conditions described in section 5 is qualitatively shown in Figure 12. The vertical lines indicate the positions of maxima. Their magnitudes cannot be given at this time. This indicates that a large portion of the membrane responds to comparatively simple stimuli when they are loud.

12. *Discussion.* A tentative interpretation of the principal pertinent data available has been made in terms of the theory that the cochlea separates vibrations according to their frequencies, projecting them so to speak, from the stapes through their various appropriate regions of the basilar membrane where they are

direct methods such as those in this paper. Many details as given here might with equal justification have been varied quantitatively to

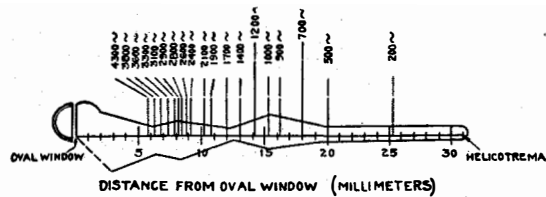

Figure 12—Combinational Tones

a certain extent. It is hardly worth while going into a further discussion of these details in view of the limited amount of applicable data upon which they depend.

It might be well to explain a little more in detail the general features of the mode of per-

ception of relative pitch and intensities. The brain is assumed to detect differences in pitch simply by experience in associating the stimulation of different groups of nerves with different pitches. Differences in intensity may be detected either by the violence of agitation of nerve terminals at the position of its characteristic maximum or by bringing into play new terminals at the sides of the peak which at lower intensities are subject to subaudible stimulus or more likely both. It is often observed that a small change in intensity is mistaken for a change in frequency. This means that the brain can detect very small changes in position or altitude of the vibration curve of the basilar membrane, but cannot distinguish between these changes unless they exceed a certain definite amount.

The exact position of the maxima on the membrane must vary with intensity because of the varying effect of non-linearity. All curves given in this paper are located on the membrane by means of the sensibility curve at 100 times the minimum audible amplitude. The exact location of these maxima is also quantitatively uncertain as already stated because of a lack of the knowledge of distribution of sensory terminals on the membrane and the relation between this distribution and the minimum detectable distance between maxima. The frequency sensibility and the widths of the peaks of vibration might be expected to be related. The fragmentary data bearing on this point show no simple agreement but the frequency sensibility is the most logical to use at this time in determining the location of frequency response on the membrane.

Nothing has been said of the action of the apparatus of the middle ear. The data given here do not directly bear on that problem. If the minimum audible stimulating motion at all nerve terminals is the same, then the dotted curve of Figure 10 obtained from minimum audibility gives the frequency characteristics of the combination of middle ear apparatus and cochlea. A determination of the mechanics of this combination or its elements will probably have to be done indirectly from this standpoint.⁹

⁹ It should be obvious, contrary to an impression apparently created (J. P. Minton, *Phys. Rev.* 22, 506, Nov., 1923) in the discussion of this subject at the April, 1923,

APPENDIX—APPARATUS AND METHOD

The apparatus was essentially the same as previously used in this laboratory in the determination of the frequency-sensitivity of normal ears.¹⁰ An air damped telephone receiver was used as the sound source. The currents at different frequencies were supplied by means of special vacuum tube oscillators equipped with filters to eliminate effects due to harmonics. Two voltage attenuators were used, one for the primary, and one for the secondary frequency. These attenuators were of the dial type reading voltage directly on a logarithmic scale and having a total range of 1 to 10⁶. In taking data on masking for both tones in the same ear the output of the attenuators was connected in series with the receiver. In this way it was possible to vary the receiver voltage for each frequency independently. The minimum audible voltage for each frequency was separately determined, keeping the other considerably below minimum audibility. The primary voltage was then kept constant at different levels above minimum audibility while the secondary was gradually brought up from below minimum audibility until its presence produced a just noticeable change in what was heard while listening to the primary. The ratio of the just detectable voltage of the secondary in the presence of the primary to the minimum audible voltage of the secondary was taken as the corresponding pressure ratio, hence the amount of masking as defined in Part I was found. The ratio of the primary voltage as used to its minimum audible voltage give its magnitude. In the case of tones in opposite ears the procedure was nearly the same. Two receivers, one for each ear, were used in connection with separate attenuators. The primary tone in one ear was set at a definite magnitude above minimum audibility for that ear, and the amount of masking of the secondary tone in the opposite ear observed.

meeting of the Physical Society at Washington, that our assumptions attribute masking ultimately to an inability of the brain to perceive separately, two stimuli on the basilar membrane which are caused by motions of this membrane bearing the relations given in section 10 of this paper.

¹⁰ Fletcher and Wegel, *Phys. Rev.* 19, 553, June, 1922.

Modern Methods in Train Dispatching

By J. C. LATHAM

Engineering Department, Western Electric Company, Inc.

THERE is no problem of greater interest to railroad officials than that of the dispatching and controlling of trains.

When the first trains were put in operation in the early years of the 19th century, the problem of train dispatching was a simple one. It consisted simply of making sure that the track was clear as far ahead as the engine driver could see. The train started when it was ready and reached its destination when it got there. There was no schedule and there could be none because of the uncertain operation of the locomotive mechanism. Delays were expected, and even coming up to expectations they could not cause much discomfort to passengers inured to the hardships of travel by horseback or stage coach. As soon, however, as the "Railway Mania," as railroading was called in the early days, seized the world, and the railroad companies began to run two trains on a single track at the same time, starting them from opposite ends of the line, it became necessary to devise a scheme for keeping them from meeting each other, head on, or else meeting at some point where they could not pass.

To avoid such difficulties, trains were run on the "Time Interval" system. This is the system under which the ruling train had the right of one hour against an opposing train of the same class. If the latter did not appear within the hour the train left the siding and went on, sending a flagman some distance ahead as fast as his legs could carry him to flag the opposing train. When the two came within sight of each other one of them had to go back to the nearest siding. Obviously, a great deal of time was lost if trains were late, an occurrence always more than likely.

Increased traffic soon rendered impossible the continued operation of trains by means of the time interval system. It was then that the world sought recourse to other means from which there are two survivors today, the Telegraphic and the Staff systems. For three quarters of a century these systems have served the railroads. To meet increased traffic com-

plications, both have been modified to meet new conditions, but both today seem to have reached the extent of their possibility for improvement, while railroad traffic congestion becomes steadily greater.

If efficiency of railroad operation is to increase, more modern facilities must be sent to the aid of these pioneers. A large number of the railroads of the world have already recognized this fact and are gradually adopting a newer system of communication, one which has already become absolutely necessary for handling so many of the other great communication problems of the world—the telephone.

The successful adaptation of the telephone to the purpose of train control required the

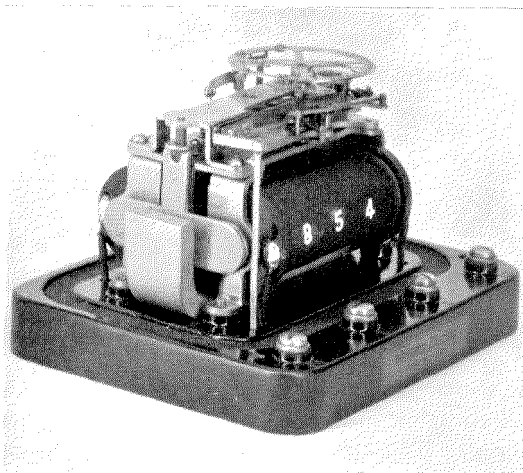

Figure 1—Telephone Train Dispatching—Selector

solution of many problems that in the commercial telephone system do not need to be considered. The comparatively great distance between stations makes the use of individual lines impossible both on account of the great expense of installation and maintenance. The only practical method was found to be the placing of a number of stations on the same telephone line. But, even this arrangement did not prove satisfactory on account of the

complicated system of code ringing necessary to enable the controller to call individual stations and the disturbance at all stations whenever a call was being made. That so large a number of railroads in the world today use the telephone for train control shows that this difficulty has at last been obviated.

This result has been accomplished largely by a simple piece of apparatus, small enough to hold in the hand—the Western Electric Selector. This little instrument consists of a simple electro-magnetically operated stepping mechanism which permits of the calling of any station without affecting the others. Its operation is controlled by impulse sending keys at train controller's office which step any desired selector up to the "ringing position," where it remains for about two seconds. Dur-

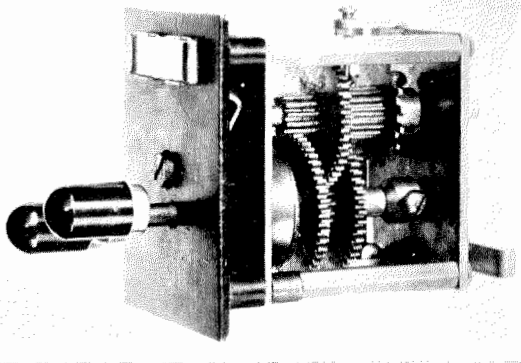

Figure 2—Telephone Train Dispatching—Selector Key

ing this ringing period a tone is produced in the controller's telephone receiver giving him an indication that he has reached the station desired. The controller employs either a telephone receiver provided with a headband or a loud speaking horn type receiver. The receiver of whichever type used is kept constantly connected to the line. The keys corresponding to all the way stations on the line are installed in a small cabinet within easy reach of the controller. This arrangement makes it possible for the controller, during a conversation with one station, to call additional stations on the line and the fact that the dispatcher's receiver is kept always connected to the line permits any way station in case of emergency to break in on the conversation. Where desired, it is

possible to provide a key of the same type permitting the dispatcher to call all stations on the line simultaneously without having to operate all of the individual keys. It is also possible

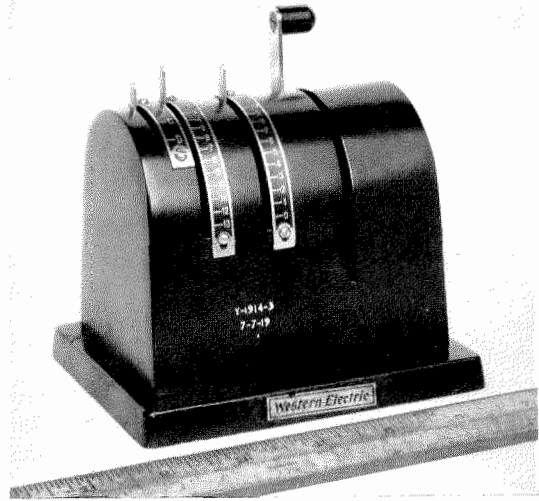

Figure 3—Telephone Train Dispatching—Master Selector Key

by the use of additional equipment to arrange for intercommunication among all of the way stations.

The wiring for the selector system of train control not only takes care of the telephone train dispatching but by means of a simplex or phantom arrangement permits its simultaneous use for telegraphy as well.

A simplex circuit is one obtained through the use of repeating or retardation coils connected to the telephone circuit. A simplex circuit may be used for telegraph communication without interfering with telephone conversations going on at the same time over the telephone line. A phantom circuit is a circuit obtained by connecting repeating or retardation coils to two existing metallic telephone circuits in such a manner as to provide a third telephone circuit. By means of this arrangement, three telephone conversations may be carried on at the same time.

The telephone, together with the selector calling apparatus, constitutes a system of communication which has many advantages in the control of trains. Accuracy in transmitting orders or information is assured by the practice

of having the controller write down his words as they are spoken and checking this written record as the order is repeated back by the operator who has also written it down. By this method, complete reports of the passing, arrival or departure of trains can be given in the fractional part of a minute and informa-

headquarters in case of a breakdown or other accident occurring between stations. The portable telephone has also proved of great assistance in the work of construction or repair gangs. By calling up the controller the foreman of such gangs can lay out the work of his men to fit in between the scheduled passing of trains,

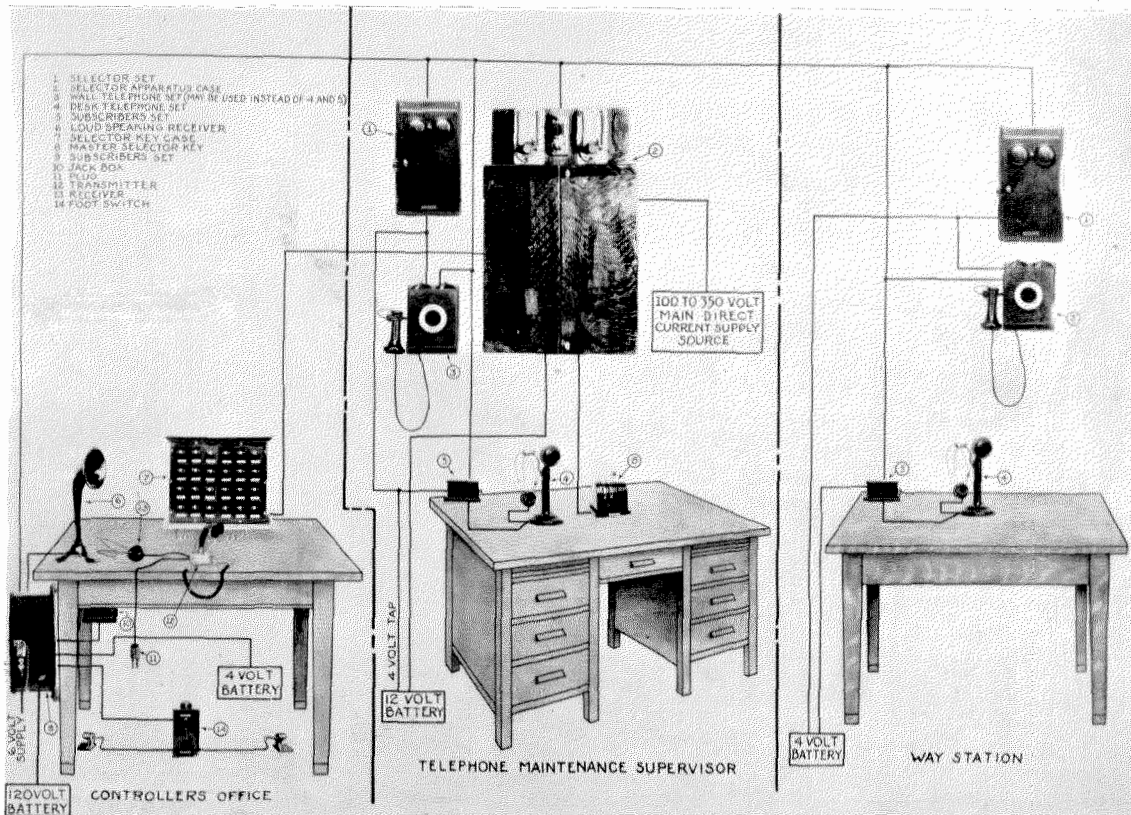

Figure 4—Telephone Train Dispatching—Layout

tion regarding accidents or other occurrences outside of the daily routine may be sent to headquarters verbally in such complete form that the necessity for additional messages is eliminated. In the handling of locomotives, this system has proved especially valuable, aiding greatly in approaching the ideal condition of keeping all locomotives constantly at work and drawing full loads.

The use of the telephone, however, is not limited to controllers and way station operators. Portable telephones are supplied to the crews of passenger and freight trains. These enable such crews to communicate immediately with

and can quickly communicate his orders for supplies or material. Another and possibly more important service performed by the portable telephone is its use by track inspectors. There are many instances recorded in which serious accidents have been avoided as a result of telephone reports of the discovery of wash-outs, landslides and other sources of track troubles. Telephones at sidings have also been found to be of great value by making it possible for the train crews to notify the controller of their movements. On single track roads, siding telephones are practically indispensable for maintaining a clear right-of-way.

Single track roads which carry great quantities of perishable freight find in these siding telephones the one way to facilitate shipment. By

means better service can be given to shippers and consignees.

The use of portable and siding telephones in



Figure 5—Telephone Train Dispatching—Portable Telephone

obtaining instructions from the controller by means of siding telephones, the conductors of such trains are enabled to leave sidings and follow directly after passenger trains. By this

connection with the regular controller and way station telephone apparatus has proved to be a great factor in increasing the operating speed of the railways. Unaccountable delays are im-

possible on any road equipped with the telephone as the entire right-of-way is always within telephone reach of the controller.

In order to show how this selector train dispatching system meets the different conditions

control problems, and seems likely, without major changes, to be able to handle such problems far into the future.

On British railroads, the standard practice differs considerably from that in use on rail-

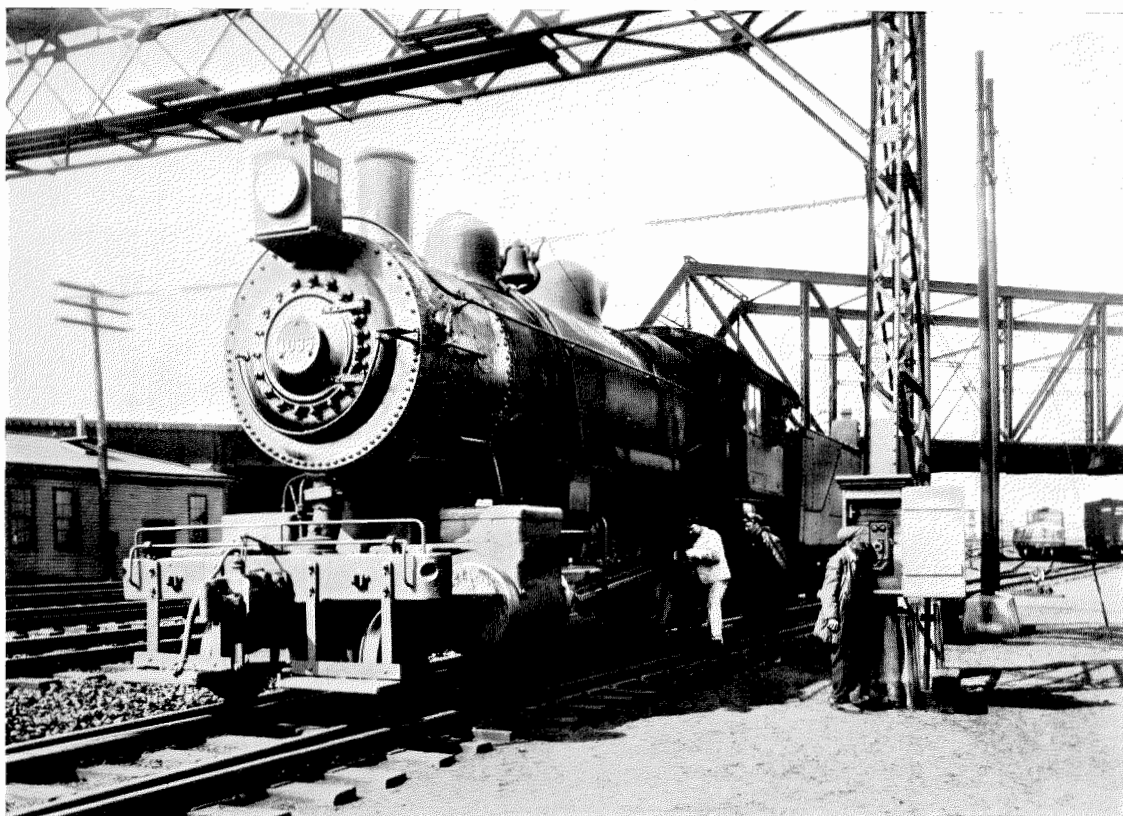

Figure 6—Telephone Train Dispatching—Siding Telephone

met with in railway operation, it may prove interesting to describe some of the installations of this system on railroads in different parts of the world.

In the United States and in Canada, where the use of this system is universal on all main line railroads, the system of train control employed is that in which the controller or dispatcher, as he is called, has actual charge of the dispatching of all trains within his division, which consists ordinarily of 100 miles or more of the line. This system, which was developed gradually with the North American railways, has, since the adoption of the selector train dispatching system as a means of communication, proved amply able to take care of all train

roads in the United States and Canada. The English practice is to limit the functions of the controller to the control of non-scheduled traffic, such as freight trains, locomotives, etc. At the present time, the tendency seems to be to extend the authority of the controller more and more to include also the scheduled passenger traffic. Ordinarily, the movements of passenger trains are not interfered with unless they are running so late that other passenger trains are likely to be affected. In the office of the traffic controller, as he is called, working under the chief controller are sectional controllers, each of whom has charge of an area of the signal towers, railroad yards, locomotives and locomotive sheds, all of these having telephone connec-

tion with him. The purpose of this system of train control is to insure the prompt handling of trains, to modify train movements as may be required, to take care of emergencies, to avoid long hours of engineers and train crews and to use available locomotives to best ad-

call for medical aid, can divert traffic, cancel trains, provide another locomotive and dispose of the cars of the disabled train. Naturally each area has its own peculiarities in the way of operation all of which it would be impossible to describe in detail. However, as one example,

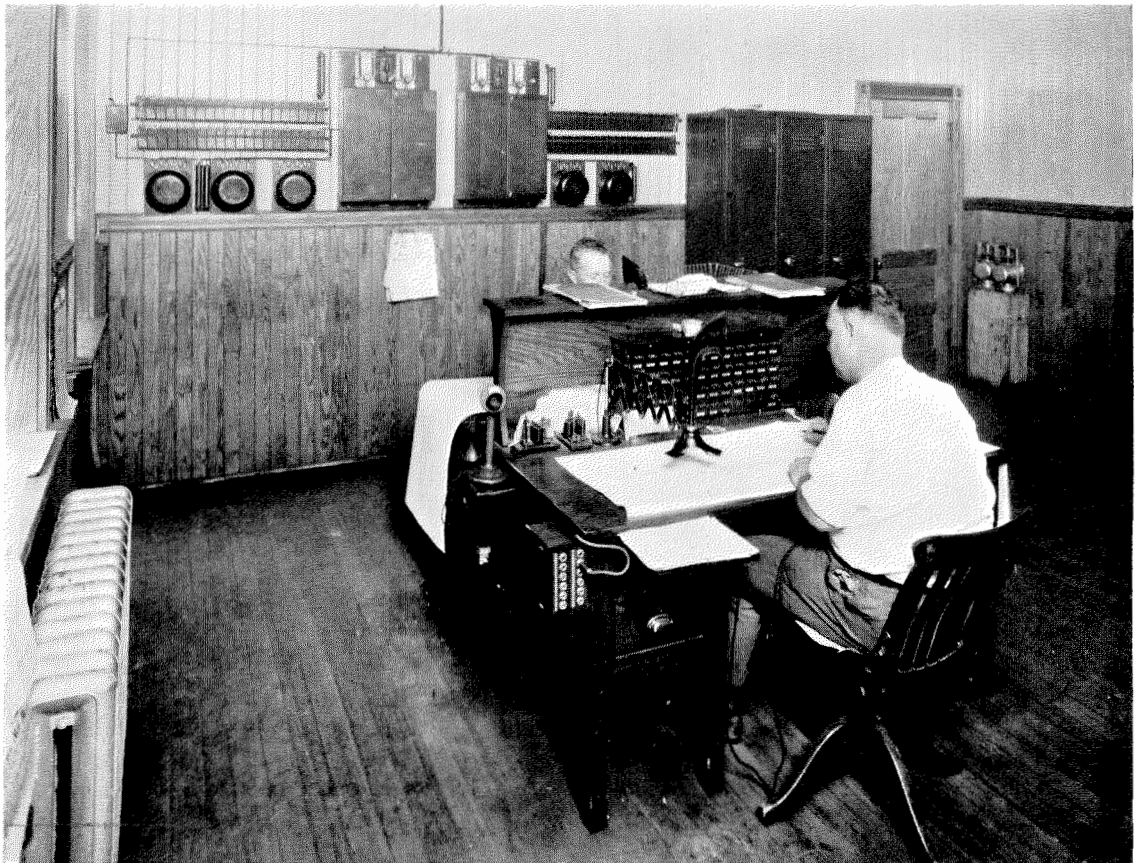

Figure 7—Dispatcher's Office—Loud Speaking Equipment Installation—N. Y., N. H. & H. Railroad—Harlem River Station, U. S. A.

vantage. The traffic controller requires, therefore, to know what trains are to be expected, what cars loaded or partly loaded are on hand, the destination of the loaded cars that are ready for shipment, the locomotives and train crews operating each train, complete information as to the nature of the freight being carried and the stations to which it is destined, also the time of arrival and departure of each train at every stop made. All this information he keeps before him in such form as to be immediately available.

In case of an accident, the controller can

there may be mentioned the case of a certain railroad engaged largely in the transportation of coal. On this railroad a single selector controlled area provides one-third of the tonnage originating on the entire system and requires from 60 to 70 locomotives to be kept constantly in operation. Altogether, some 11,000 cars are dealt with in the district during each working day of 24 hours. The handling of these requires the solution of many difficult problems in the manner of engine power. All of these problems have been successfully handled by the selector telephone system.

On British railways, the controllers generally work with a large board in front of them on which is marked the lay out of the system to be controlled. Reports of train locations keep this board constantly up to the minute.

In France, the selector train dispatching system is used as an information system to

information he transmits to the point where it is needed and uses it also to correct his graphic chart of operation.

Thanks to telephonic communication and to his graphic chart, the controller has before him continuously a picture of the movements of all the trains on the line.



Figure 8—Telephone Train Dispatching—Way Station—Interlocking Tower—U. S. A.

keep the proper authorities informed of the movements of trains and all other conditions of interest. The controller has nothing to do with the internal work of the station at which he is located, but he serves as a valuable source of information for the station master and the locomotive sheds. When a train departs, the controller is informed of the time of its departure, of the composition of the train and the number of freight cars, and of the destination of these, of the number and type of locomotives used and the sheds to which they belong. This

In Belgium,¹ the position of the controller is much the same position as in France. His function is to regulate the running of trains so as to eliminate delays and avoid blocking. Safety of traffic is assured apart from him by the system of signals which the engine drivers must obey. The controller acts as a means for

¹ See also Bulletins of the International Railway Congress Association: November, 1922, "The Telephonic Dispatching System on the Belgian State Railways," by V. Lamalle, and May, 1924, "Dispatching System by Telephone on the Belgian State Railways," by H. De Caesstecker.



Figure 9—Dispatcher's Office—Grand Trunk Railway—Bonaventure Station, Montreal, Canada



Figure 10—Nottingham Control Room—Great Northern Railway, England



Figure 11—Dispatcher's Office—Bruxelles Nord, Belgium

coordinating the measures to be taken by all of the station masters spread along the line. In Belgium, as in France, the relations of the dispatcher are with the station masters who are responsible for the actual running of trains. On

to them, and in consequence they are enabled very efficiently to dispatch trains through their respective sections. The greatest saving made possible by the use of this system lies in the greatly increased facilities at the dis-

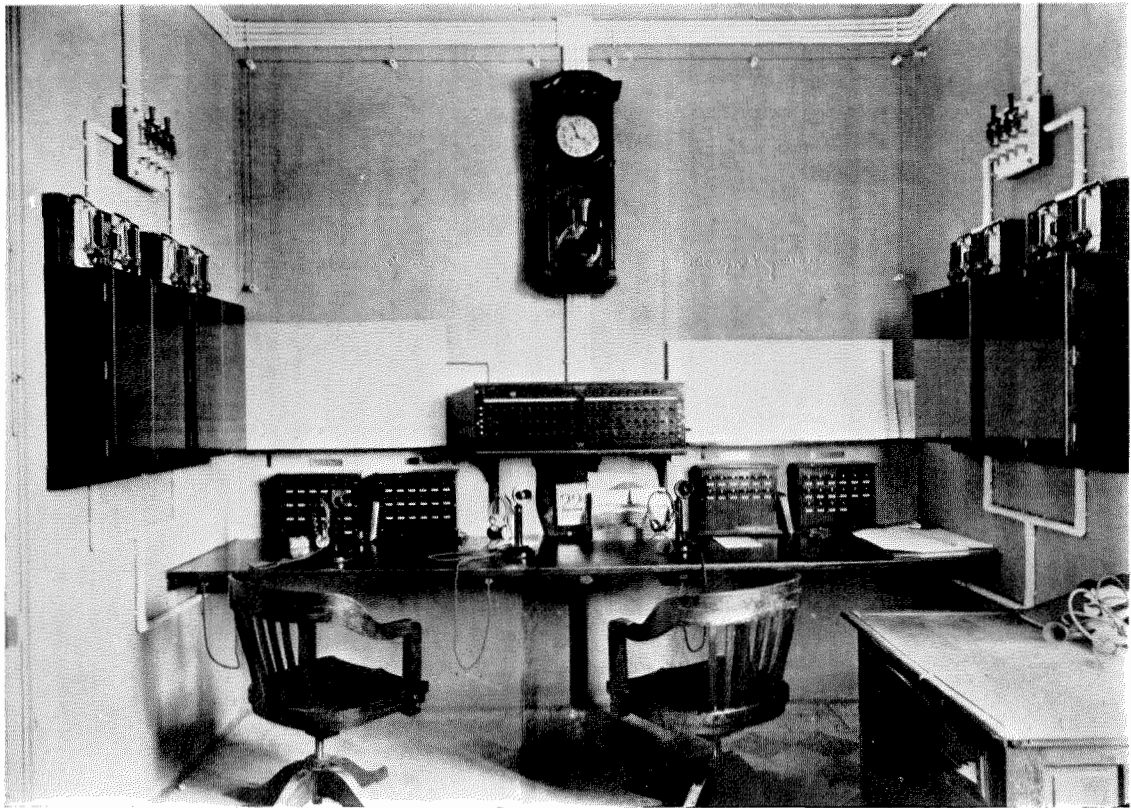

Figure 12—Telephone Train Dispatching—Controller's Station, Spain

some of the more congested of the Belgian railways, the Western Electric train dispatching system has been installed in such a way that a separate controller controls the traffic in each direction.

In Spain, the telephone train dispatching system serves the purpose for which it is generally used all over continental Europe, that is, the controller, or as he is sometimes called, the information officer acts in an informative and not in an executive way. He gives information to the various station masters who retain full control and authority over their respective stations. Thus, station masters welcome the service of the train control system since they can always be put in touch with whatever train movements may be of interest

positional of station masters for controlling the make-up of freight trains. Because of this alone, the electrical department of one railroad reports that the system has saved its entire cost in one year.

As employed in Scandinavia, the Western Electric train dispatching system is used as part of the information service as in most other continental countries.

In Denmark, the installation is so arranged that all way stations are provided with master keys enabling any way station to call any other way station directly.

On the Italian State railways the telephone train dispatching system is installed on lines totaling in length more than 75,000 kilometers, the system being installed in various ways on

different lines. On some lines there is installed the standard train dispatching system employed in connection with the train control information service as in the rest of continental Europe. Other lines are equipped, as in Denmark, so that each way station may communicate directly with any other way station.

In South America the Western Electric

In Japan, the installation of the Western Electric telephone train dispatching system had its beginning only recently, but already the success of this system both from the standpoint of efficiency and economy has been so great that with the equipment in the course of installation the system will cover a total of 7,300 miles.



Figure 13—Telephone Train Dispatching—Goteborg Dispatching Office, Sweden

system of train dispatching is most extensively used on the State railways of the Argentine Republic. In this country the system is used for dispatching trains over approximately one-half the trackage of the Republic and further installations are taking place at the present time. The system of control in the Argentine Republic is much the same as in the United States and Canada, that is, the dispatcher actually controls the trains instead of serving only in an informative capacity to aid the station masters in such control. In addition to telephonic communication, the circuits are so arranged as to provide telegraphic service as well.

In India, this system is installed on various railways over a total trackage of 7,000 miles. It covers 82 dispatching stations and 2,038 way stations. The installation is much the same as on the English railways.

Besides the countries named above in which the Western Electric telephone train dispatching system is employed, the Roumanian State Railways have recently ordered equipment for 72 stations covering a total of 595 kilometers of line and a trial installation is being undertaken over a short line in Czechoslovakia.

In addition to its use on the steam railways of the world, the Western Electric telephone

train dispatching system is used in many localities for the control of tramways. The installation of this system on the London County Council tramways² is probably the greatest tramway control in the world. In this one installation the control covers about 750 cars and includes 164 way stations. The same system also finds extensive use in under-

² *Electrical Communication*, Vol. II, No. 2, October, 1923, "Telephone Traffic Control for Tramways."

ground railways, the most recent installation being that in the Glasgow Subway.

The above list of installations by no means includes all of the countries in which the Western Electric telephone train dispatching system is to be found, nor all of the uses for which it serves, but it will give some idea of the flexibility of the system and its adaptability to the communication problems connected with train control.

Wave Form Examination with the Cathode Ray Oscillograph

By N. V. KIPPING

European Engineering Department, International Western Electric Company

THE earliest types of oscillograph would probably never have been developed had it not been for their particular adaptability to wave-form examination, for this has been their most important application both in the laboratory and in commercial use. For the examination of wave-shapes of alternator outputs; for the investigation of transients, whether non-recurrent or otherwise; for medical work on audition; for telephonic distortion experiments and for a multiplicity of other purposes,—a device of this kind is today a necessary aid to investigation. Consequently, the chief need to be kept in view when seeking to perfect the Cathode Ray Oscillograph¹ is the provision of means to adapt it to wave-form examination.

As compared with the older vibrating-strip type of instrument, the Cathode Ray Oscillograph has many advantages; for instance, its ability to deal with radio frequencies and its two-directional control over the vibrating element, the Cathode Ray. That these improvements in detail should be retained, while the instrument is at the same time rendered adaptable to the particular, yet highly important, application of wave-form examination, is of great importance.

In the older vibrating-strip type of instrument, the deflection of the vibrating element could only be effected in one direction, proportionally to *one* varying force. When it was necessary to examine the way in which this variant changed with time, that is to say, when the wave-form of the variant was required, an external means had to be found for spreading out the wave proportionally with time. For this, a mirror rotating at constant speed was used; or when a photographic record was to be made, a falling or projected photographic plate was utilized. The cumbersomeness of these was frequently inconvenient.

With the Cathode Ray Oscillograph, the provision of a second pair of deflecting plates, enabling the ray to be deflected in two direc-

tions at right angles, results in the production of a curve in rectangular co-ordinates. For wave-form examination with this oscillograph, one pair of deflecting plates is used for obtaining the unidirectional deflection from the variant to be examined: across the other pair of plates must be connected some electrical circuit which will deflect the "spot" in a direction at right angles to the motion due to the variants, in a manner which is proportional with time, or, alternatively, the deflection might be obtained by some external electromagnetic arrangement rather than by the electrostatic means above described. If this is done and if the frequency of recurrence of the "time" deflection can be synchronized with the frequency of the unknown variant, a stationary picture of the wave-form is obtained on the oscillograph fluorescent screen.

There arises, however, the question of the manner in which the "time" deflection is itself to vary with time. The wave-shape of the time-deflection itself is clearly of great importance, the representation most familiar being that in which the time-scale is even. There might, however, be logarithmic, sinusoidal, or other time-scales. The production of a sinusoidal time-scale for the oscillograph would, indeed, be very simple, but the fact that such a system is unfamiliar would render the resulting figure complicated and it would, for practical purposes, have to be translated to the even scale after having been recorded.

It is interesting to follow the work which has been done in finding a means of producing a satisfactory time-scale for the Cathode Ray Oscillograph. The elusiveness of the circuit which would produce the even time-deflection has led some investigators to use some of the less familiar scales. An obvious possibility for an even time-scale was a potentiometer connected across a battery, the deflecting plates of the oscillograph being connected between the moving contact of the potentiometer and the center point of the battery. By rotating the potentiometer contact at constant speed an

¹ *Electrical Communication*, Vol. I, No. 2, Nov., 1922.

even scale time-deflection was obtained on the oscillograph, but mechanical considerations forced a rather low frequency limit to the rate at which the contact might be revolved—namely, about 1000 cycles per second. This, however, was an improvement on the limit of speed of about 100 cycles for an external revolving mirror, or still lower speeds for the moving photographic film or plate.

A successful method was by the discharge of a condenser through a valve, the frequency being governed by an interrupter. This system has probably more value for laboratory than for commercial use as it is more costly and requires more battery power than a method to be described later.

A more complicated method which produced a polar diagram of the wave-shape was patented in England by Professor J. MacGregor Morris of East London College. This device uses a synchronous motor in conjunction with the oscillograph for the examination of, say, an A.C. Supply. The motor is driven off the supply in question and is arranged to cause an extra pair of deflecting plates, arranged outside the tube, to rotate round the Cathode beam at a rate of once per cycle of the A.C.

The resulting trace is a circle (for a pure sine wave) passing through the undeflected position of the "spot." This circle is described twice per cycle. For the second harmonic alone, the curve consists of four symmetrical loops intersecting at the undeflected position of the "spot." For the (n th) harmonic, there are ($2n$) loops when (n) is even and (n) loops when (n) is odd. The odd numbered loops are described twice per cycle and the even numbered loops only once.

Thus it will be seen that for an alternator with several harmonics a complicated curve is obtained, compounded of the circle and various loops, with their correct scale and phase relations. The polar diagrams are, therefore, somewhat difficult of translation and it is clear that, for ordinary purposes, something more simple and direct is necessary.

A very interesting method tackles the problem from an entirely new angle. To the two pairs of oscillograph plates is connected the circuit of Figure 1 in the manner shown. The values R and $\frac{1}{C\omega}$ are arranged to be equal, so that

equal deflections 90° out of phase are obtained from the oscillograph plates. The resulting trace is a circle, assuming that the wave-form of the known A.C. concerned is sinusoidal. The "spot" tracing the circle is, of course, rotating at a frequency equal to that of the A.C. applied. The circuit has been called a "rotator circuit," so that the frequency of rotation is the rotator frequency.

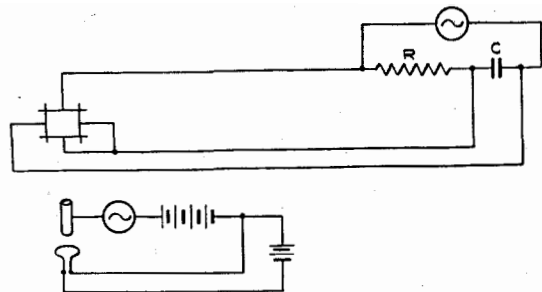

Figure 1—Rotator Circuit

The fact is now made use of that the sensitivity of the oscillograph varies inversely with the anode voltage; in other words, the diameter of the circular trace made by the rotator circuit is greater with an anode voltage of, say, 250 volts than with a voltage of, say, 300 volts. The unknown A.C. wave is, therefore, superposed on the D.C. anode battery, the two being connected in series. The anode voltage is now varying between two limits $A+B$ and $A-B$, where A is the D.C. anode battery, and B is the A.C. voltage of the A.C. connected. This arrangement results in variations in the diameter of the circular trace according to the value at any instant of the unknown A.C. Suppose that the unknown A.C. is exactly 10 times the frequency of the rotator frequency, then 10 times in each revolution of the spot, the anode voltage is $A+B$, and at other 10 times in the same revolution it is $A-B$ volts. Furthermore, as the relationship of the two frequencies is exactly 10:1, the places in the circular trace at which these extremes of diameter (resulting from corresponding extremes of anode voltage) occur are the same in each revolution. The result of this is that a gearwheel type of trace is produced, the number of teeth to the wheel being a measure of the number of times that the unknown A.C. frequency is of the rotator frequency.

Clearly, the shape of the teeth in the wheel is dependent on the wave-shape of the unknown A.C., a nearly exact reproduction being obtained. Although the time-base is even, it is not straight, and the waves are slightly distorted by this curvature in the time-base. Figure 2 shows the type of result obtained by this method.

While considering this system, its great utility for purposes of frequency comparison should be observed. The more usual method of frequency comparison consists in applying two A.C. frequencies, one to each pair of the deflecting plates; one of these frequencies is known, the other unknown. When the frequencies stand in some relationship to one another, such as 5:3 or 6:1, the trace produced on the screen is the appropriate Lissajou figure. If this relationship becomes complicated, how-

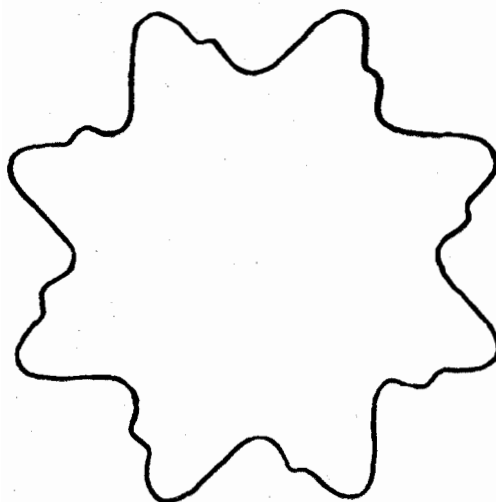
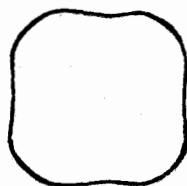

Figure 2—Rotator System—Wave Examination

ever, the trace is extremely difficult of translation.



3-1



4-1

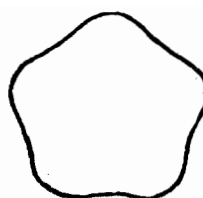

5-1

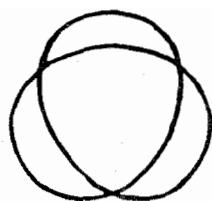

3-2

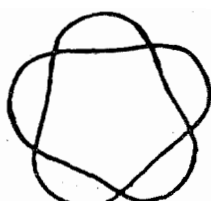

5-2

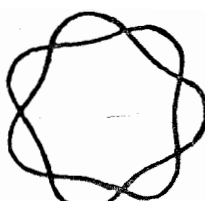

7-2

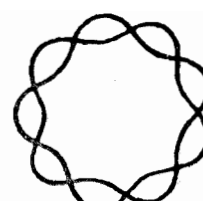

9-2

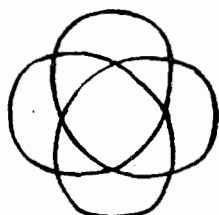

4-3

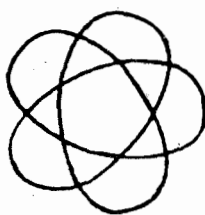

5-3

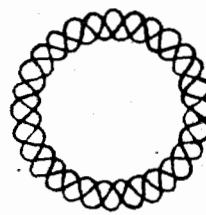

28-3

Figure 3—Rotator System—Frequency Measurement

With the rotator method of frequency comparison, the number of teeth in the wheel gives the frequency relationship when one frequency is a rational multiple of the other. By suitably changing the relationship of the two frequencies concerned, it is possible to obtain figures on the screen which are easily interpreted, such as those shown in Figure 3, in which the relation-

used for advertising purposes (with the bright electrode made to represent a letter or figure.)

In this circuit, the potential difference across the lamp gradually builds up to the critical striking voltage of the lamp, then falls below this value, so that the lamp alternately strikes and fails. When the voltage is switched on, the lamp may be said to be on open circuit; and

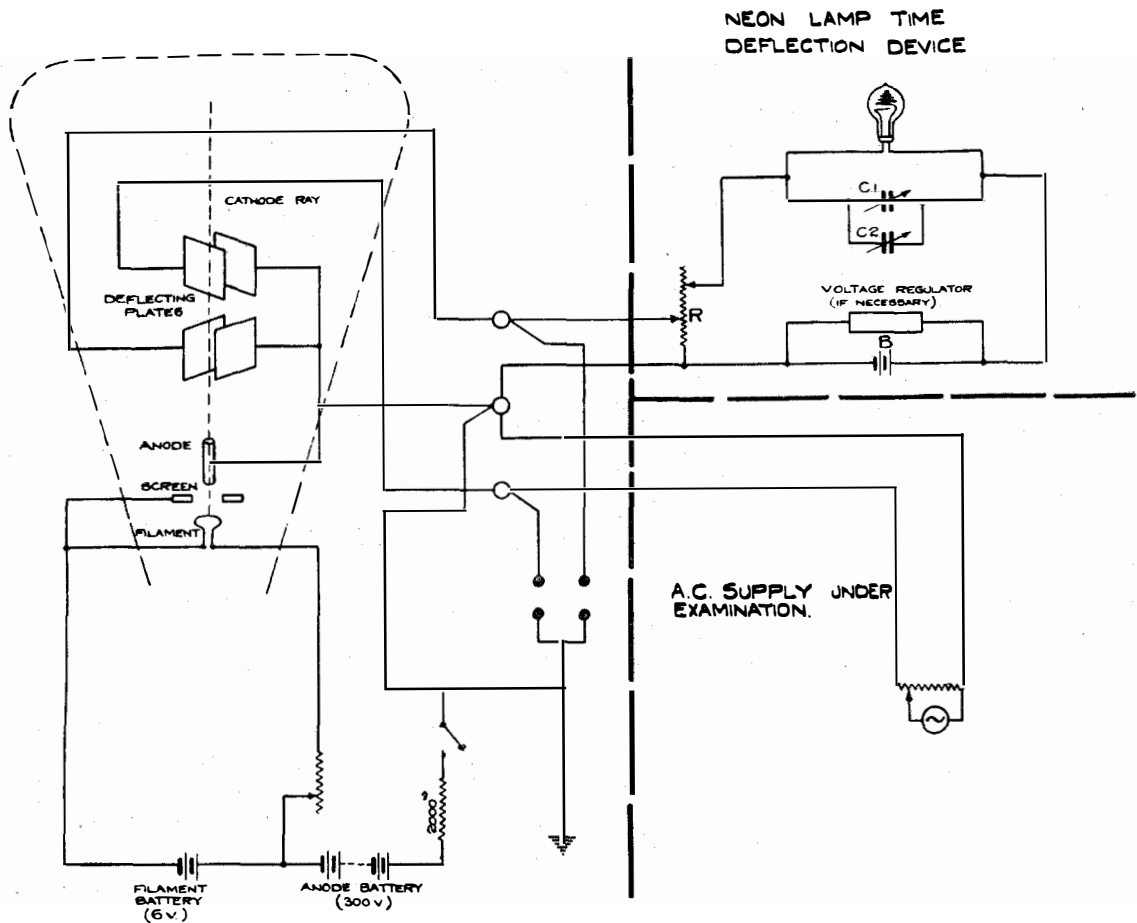

Figure 4—Neon-Lamp Time-Deflection Device

ships are indicated. The system of the tracings is obvious from these figures.

Perhaps the most generally useful method for providing the time-base is one which depends upon the property of the neon-filled lamp, or similar devices, of "striking" only when a certain voltage is reached, the discharge "failing" again at a second potential lower than the striking value. In Figure 4, this time-deflection circuit is shown applied to a pair of the oscillograph plates. The lamp is one of the common neon-filled glow-discharge type, much

the potential difference (e) across the condenser and, therefore, across the lamp at any time (t) will be given by:—

$$e = B \left(1 - e^{-\frac{t}{rc}} \right)$$

where B , r and c are as shown in Figure 4.

The potentials at which the lamp strikes and fails being known, the frequency of the blink may thus be easily determined. The obvious necessity for constancy, in the 200 volt neon lamp supply battery, prevents the use of current from mains for this circuit, unless a voltage regulator is also used.

A suitable proportion of the potential variations, occurring in the series resistance, is applied to the oscillograph plates governing horizontal deflection. The potentials in this resistance follow the charge and discharge curves of the condenser. As, however, owing to the limits in potential imposed by the neon lamp in parallel, the condenser is never fully charged or discharged, only parts of the curves are made use of and these parts approximate to a straight line. Therefore, the time-base produced by this

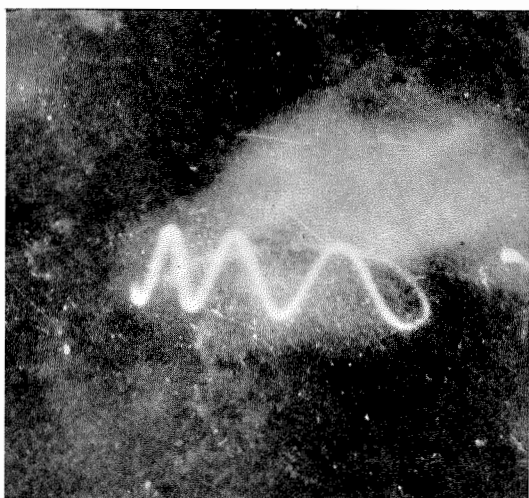

Figure 5-A—Wave-form—1500~Filtered

method is not precisely even, but is sufficiently close for a very nearly undistorted reproduction of a wave to be obtained. The actual effect which occurs is a slight shortening of the time-scale in one direction; this results in a slight crowding up of the waves in one direction.

The three photographs shown in Figures 5 A, B and C demonstrate this effect and show that the difference between shape in one wave and the next, in this system, is sufficiently small for the method to retain its value. The great simplicity of the system is in its favour, especially for commercial users for whom other systems mentioned are unsuitable.

Figures 5 A, B and C are photographs of the outputs from various vacuum-tube oscillators. In A and B the oscillator frequency was 1500 cycles, in A the output being filtered. The improvement in wave-shape brought about by the filter can be clearly seen from the difference in shape between the unfiltered wave in

B and the filtered wave in A. Figure 5-C is the output from an oscillator designed for high frequencies, being used at the comparatively

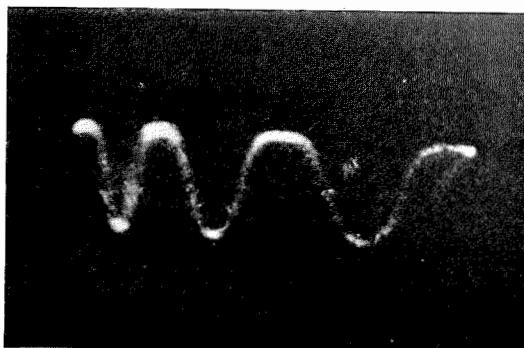

Figure 5-B—Wave-form—1500~Not Filtered

low frequency of 7500 per second, by introducing a high value condenser. For this photograph, as there are three complete waves shown, the neon lamp frequency was adjusted to one-third of 7500, or 2500~per second.



Figure 5-C—Wave-Form—7500~

These photographs demonstrate the accuracy with which the neon lamp frequency can be tuned by adjustment of the parallel condenser. The exposure used was four minutes using $f/4.5$ and it was, therefore, necessary that the pattern should remain stationary for this length of time.

The slight distortion which this system does introduce into the time-scale may be greatly

reduced, but only at the expense of simplicity of operation. For this, the series resistance in the neon lamp circuit may be replaced by a two-electrode vacuum tube. In this arrangement a condenser charges periodically through the vacuum tube, the frequency of successive charges being governed by the filament temperature of the vacuum tube and the size of the shunting condenser. The filament of the tube is kept at such a temperature that the current through the tube is constant and independent of the voltage over most of the discharge range.

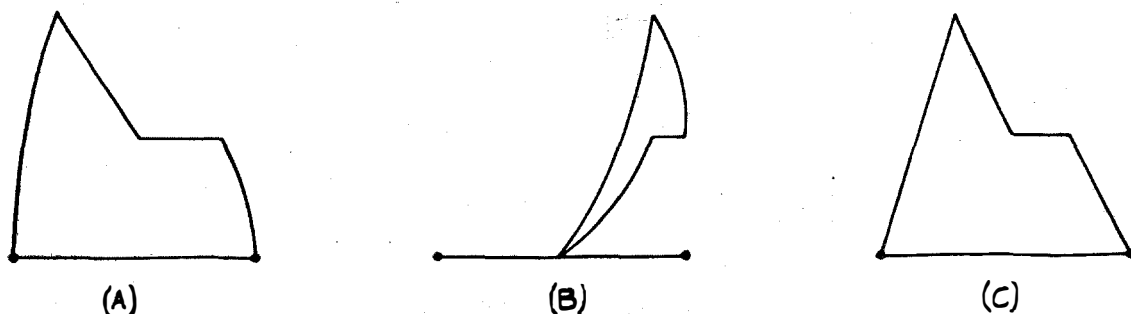

Figure 6-A, B, C—Comparison of Sine and Even Time-Bases

Such an improvement in the time scale is in the nature of a refinement which would be advantageous where a high degree of accuracy might be desired, but generally for commercial purposes, such as examining the wave-forms of commercial alternators, the series resistance in conjunction with the neon lamp will probably be found to be sufficiently accurate.

An instance where extreme accuracy is of importance, however, has arisen in the most valuable research work of the Radio Research Board of Great Britain (Department of Scientific and Industrial Research) on the nature of wireless atmospherics. In this work, Mr. R. A. Watson-Watt and Mr. J. F. Herd, of the Radio Research Board, have been associated with Dr. E. V. Appleton, of Cambridge University. The frequencies required ruled out the rotating potentiometer and other time-deflection devices. (It may be mentioned that the neon lamp system may be used at frequencies at any rate as high as 10,000 cycles per second. For wave-form examination, as many as 10 complete waves may be comfortably viewed on the screen together. It is considered that waves of fre-

quency about 100,000 cycles per second might thus be examined, but actual observations have so far not exceeded 50,000 cycles.)

In the earlier days of the Radio Research Board's work no satisfactory even base was known and a sinusoidal base was used. To enable an intelligent study to be made, however, all the curves recorded by means of a sine base had to be translated to the linear system. In Figure 6, both A and B produced on a sinusoidal time-scale will have the form C when translated to the even time-scale. The need for such a graphical translation was itself a serious dis-

advantage to the Radio Research Board, by whose courtesy these details are given.

The types of curve obtained from atmospherics with the old sinusoidal time-base fell into several groups, of which the examples shown in Figure 7 are characteristic. The time-base was, for this work, projected across the oscillograph screen a known suitable number of times per second. It is interesting to note that in (c) the duration of the stray was greater than the time taken for one swing of the time-base. The distortion produced in a case like this is emphasized, and demonstrates well the advantages of a linear base. In (e), the rise was too rapid to be visible. (k) shows a stray of the opposite sense to the other types shown. As is seen in Figure 7, the duration of the stray may be nearly estimated.²

This work is typical of one type of experiment which may be conducted when given a satisfactory time-base with the Cathode Ray Oscillo-

² A more detailed description of the results obtained in these experiments on the nature of atmospherics has already been published in the Proceedings of the Royal Society, A, Vol. 103, 1923, and in the "Wireless World" August 1st, 1923.

graph. Many other uses have from time to time arisen. The chatter of relay contacts, opened and closed at a constant frequency, may be easily seen with the time-deflection

The device has been of value, also, in the course of work on distortion introduced by transmitters. A complex tone was first examined directly with the oscillograph, and then again

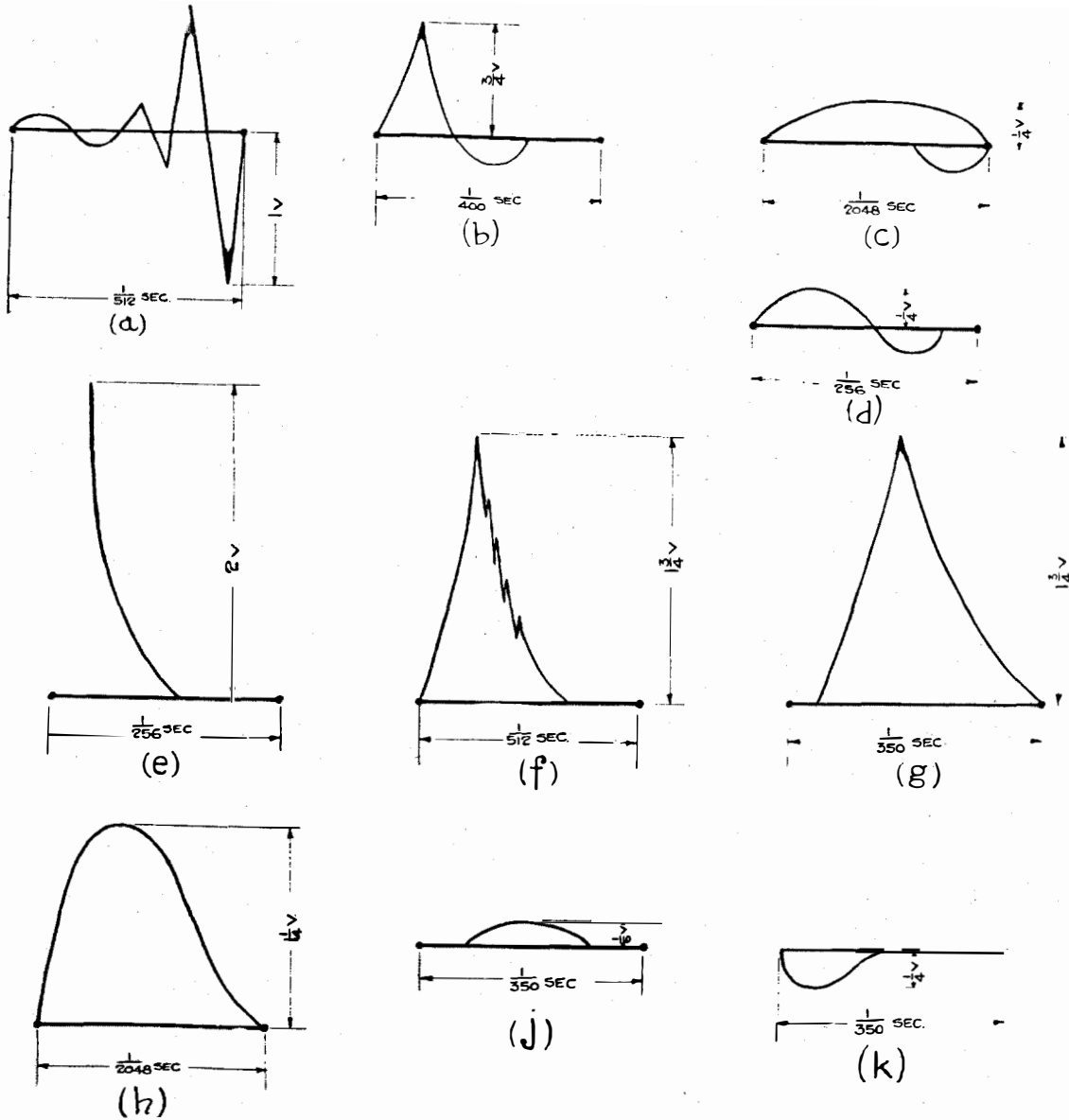

Figure 7—Deflections from Atmospherics

device. In special cases the reproduction could be arranged during adjustment of the relays, so that the best adjustment could be quickly found. This might be of special value in telegraph working, where the efficiency of operation of a vibrating relay on the Gulstad principle has been simply investigated.

after having passed through a telephone receiver and transmitter. In such cases of laboratory work, the cost of great accuracy in the time-scale may be justified, but for commercial purposes, there is little doubt that, the neon lamp system is the least costly and most satisfactory system at present in use.

International Western Electric Company

INCORPORATED

Head Offices

195 BROADWAY
NEW YORK, U. S. A.

European General Offices

CONNAUGHT HOUSE
ALDWYCH, LONDON, ENGLAND

Affiliated Companies

Western Electric Company, Limited *Aldwych, London, England*
Branches: Birmingham, Cardiff, Glasgow, Leeds, Manchester, Newcastle-on-Tyne, Dublin, Cairo, Johannesburg, Singapore.

Bell Telephone Manufacturing Company *Antwerp, Belgium*
Branches: Berne, The Hague, Brussels, Riga, Reval.

Le Materiel Telephonique *Paris, France*

Telefonos Bell, S. A. *Madrid, Spain*

Western Electric Italiana *Milan, Italy*
Branches: Rome.

Western Electric Norsk Aktieselskap *Christiania, Norway*

Vereinigte Telephon und Telegraphen Fabrik *Vienna, Austria*

United Incandescent Lamps and Electrical Company, Limited
Budapest (Ujpest), Hungary

Western Electric Company (Australia) Limited *Sydney, Australia*
Branches: Melbourne, Wellington.

Nippon Denki Kabushiki Kaisha *Tokyo, Japan*
Branches: Osaka, Dalny (Manchuria), Seoul (Chosen)

Sumitomo Electric Wire & Cable Works, Ltd. *Osaka, Japan*

China Electric Company, Limited *Peking, China*
Branches: Shanghai, Tientsin

Northern Electric Company, Limited *Montreal, Canada*
Branches: Quebec, Halifax, Toronto, London (Ontario), Hamilton, Windsor, Winnipeg, Calgary, Regina, Vancouver

Compania Western Electric Argentina *Buenos Aires, Argentina*

International Western Electric Company *Rio de Janeiro, Brazil*

Sales Offices and Agencies Throughout the World

To those interested in better communication the International Western Electric Company and its Affiliated Companies offer the facilities of their consulting engineering departments to aid in the solution of problems in Telephony Telegraphy and Radio.